

# QUALITY ASSURANCE (QA)/ QUALITY CONTROL (QC) IN AIR QUALITY MEASUREMENT (Ring Test Facility)

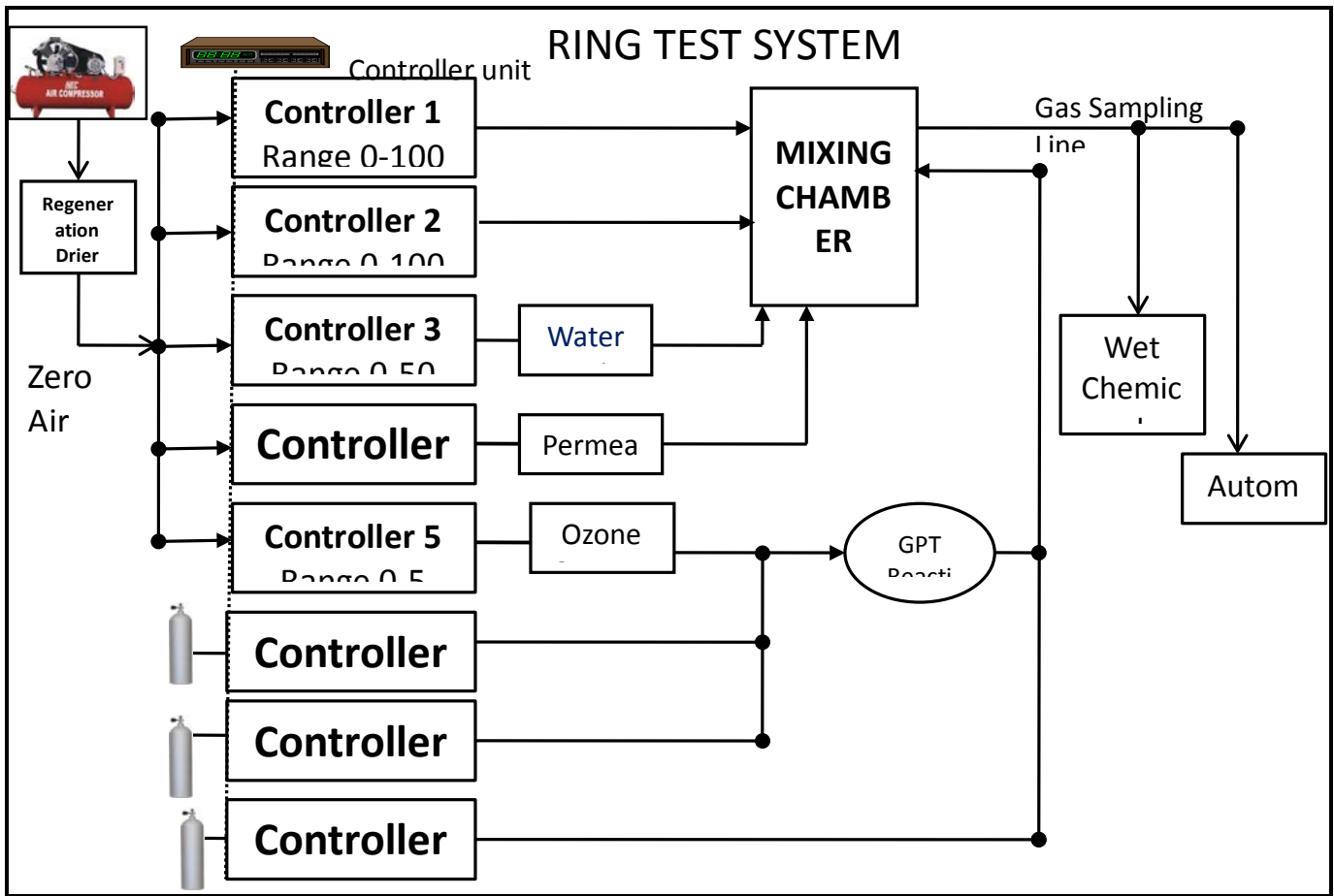

## RING TEST SYSTEM

- Ring test system is being used for conducting QA/QC exercise in Air Quality measurement.
- This system is also called a dynamic dilution system and can be used for calibration of analyzer.
- It can be used by 24 participants at a time having maximum sample flow rate 250 l/min.
- The system assures accurate mixing of gases to prepare the desired concentration in the mixing chamber as the system is controlled by precise Mass Flow Controllers (MFCs).
- Sources like Permeation tubes, highly concentrated gas standards traceable to any National or International standard can be used as primary reference gas standards.
- It contains 08 nos. of Mass Flow Controller (MFC) of different ranges.
- Different gases used for dilution of different trace gases (gas standards).
- To provide well known O<sub>3</sub> (Ozone) concentration, an O<sub>3</sub> generator with reaction chamber for Gas Phase Titration (GPT) is incorporated in the system.
- It has the facility to add different amount of moisture on the gas flow to check the influence of water vapors in the measurements.



**Static Injection System**  
**(PRIMARY CALIBRATION METHOD)**  
**ISO 6144:2001(E)**



# System Flow Chart

