

# ACTION PLAN FOR TARAPUR INDUSTRIAL AREA

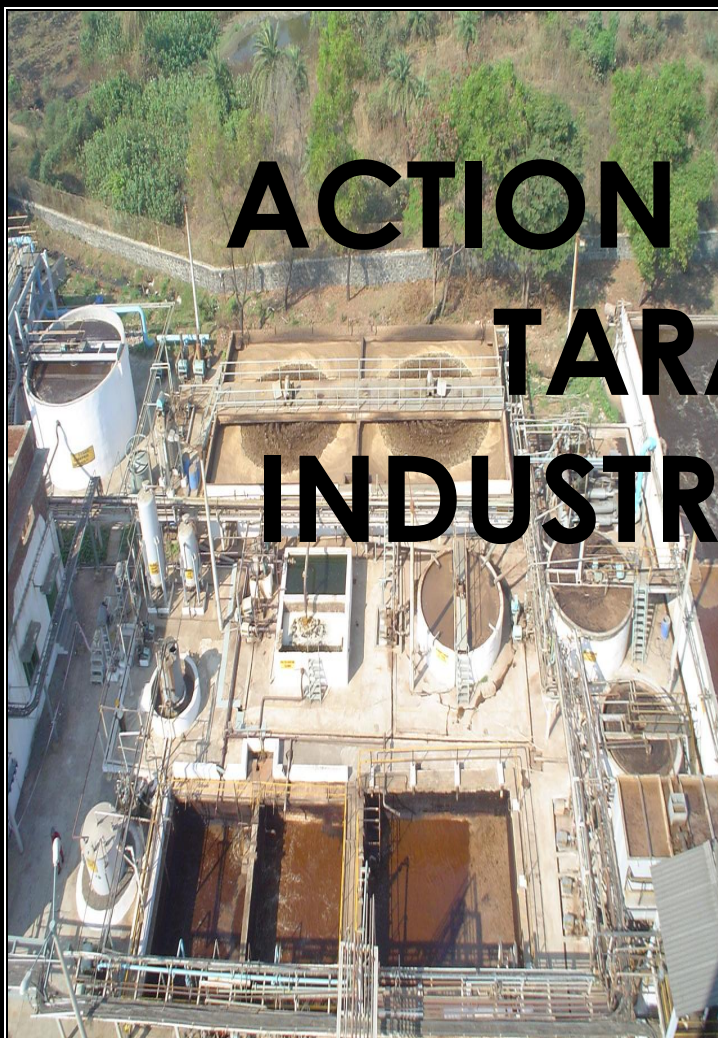

MAHARASHTRA POLLUTION CONTROL BOARD  
2010



# INDEX

<b>Sr. No.</b>	<b>Chapter</b>	<b>Content</b>	<b>Page No.</b>
1.	I	Introduction	1-9
2.	II	Water Environment	10-50
3.	III	Air Environment	51-58
4.	IV	Land Environment	59-73
5.	V	PPP model	74
6.	VI	Other infrastructural renewal measures	75
7.	VII	Specific schemes	76
8	VIII	Public Awareness and Training	77
9.	IX	Overall impact	78
10.	X	Assessment of Techno economical fesiability	79
11.	Xi	Bio composting	80
12.	XII	Summary of Action plan	81-83

## **TABLE INDEX**

1.	1.1	Population of surrounding at MIDC Tarapur	6
2.	1.2	Highly Polluting industries in MIDC Tarapur	7
3.	1.3	Red Category industries in MIDC Tarapur	8
4.	1.4	Orange, Green category of Industries in MIDC Tarapur	8
5.	2.1	Surya Surface water quality	10
6.	2.2	Ground water analysis	11
7.	2.3	Coastal water Quality	12
8.	2.4	COD load from TEPS CETP	15
9.	3.1	Ambient Air Quality Monitoring Report	51
10.	3.2	Coal consumption and APC's	54-55
11.	4.1	SWMP/ Ground water monitoring stations	59-60
12.	4.2	Ground water Quality	64

# Chapter I

## INTRODUCTION

---

### 1.1. Area details including brief history(background information)

**Tarapur** is a census town in Thane district in the Indian state of Maharashtra. It is an industrial town located some 45 km north of Virar, on the Western Railway line of Mumbai Suburban Division (Mumbai Suburban Railway). Tarapur can be reached from Boisar, the nearest railway station. It is 20 km off National Highway NH-8.

Tarapur in houses major industrial estates of Maharashtra Industrial Development Corporation, Tarapur Industrial Estate, accommodate include bulk drug manufacturing units, specialty chemical manufacturing units, steel plants and some textile plants.

Unlike other industrial estates, this industrial estate has a pleasant look due to the roads crossing at right angles and lots of small gardens adjacent to the boundary walls of the industrial units. The locations near Mumbai Port/Mumbai Harbor (BPT) and JNPT as well as proximity to Trans Thane Creek (TTC) MIDC, Vapi GIDC add a great value to this industrial estate. It is located on the most important rail-route, Mumbai to Delhi and the Mumbai-Ahemdabad Highway, a part of the Golden Quadrilateral project.

Government of Maharashtra has established Industrial Estate at Boisar Tarapur in the year 1972. This estate is known as MIDC Tarapur. This is one of the largest chemical industrial estate in the State of Maharashtra. MIDC is located 100 km away from Mumbai on the Western Railway track and 18 km away from Mumbai-Ahemdabad National Highway No. 8 in the District of Thane. The total developed area of Tarapur MIDC is 1035 hectares. The area available for industrial plots is 852.74 hectares. The area under open space 85.27 hectares. The area under amenity space is 42.64 hectares. Population in & around Industrial Area of 75 villages as per census 2001 is 1,84,345.

## **1.2. Location**

The industrial area is established in Palghar Taluka, Thane District of Maharashtra State. It lies in zone III as per seismic map of India.

Tarapur is geographically located at 17°42'N 75°28'E 17.7°N 75.47°E. It has an average elevation of 456 meters (1496 feet). The nearest Railway station is Boisar on Mumbai Ahmedabad/Delhi rail route, which is about 4 km from industrial area. It is at an elevation of average 10 m above the MSL. All the villages around is connected by excellent network of roadways. Nearest highway is NH-8 connecting Mumbai to Ahmedabad. Tarapur MIDC is approximately 130 kms from Mumbai and 17 kms off the national highway NH-8.

## **1.3. Digitized Map with Demarcation of Geographical Boundaries and Impact Zones**

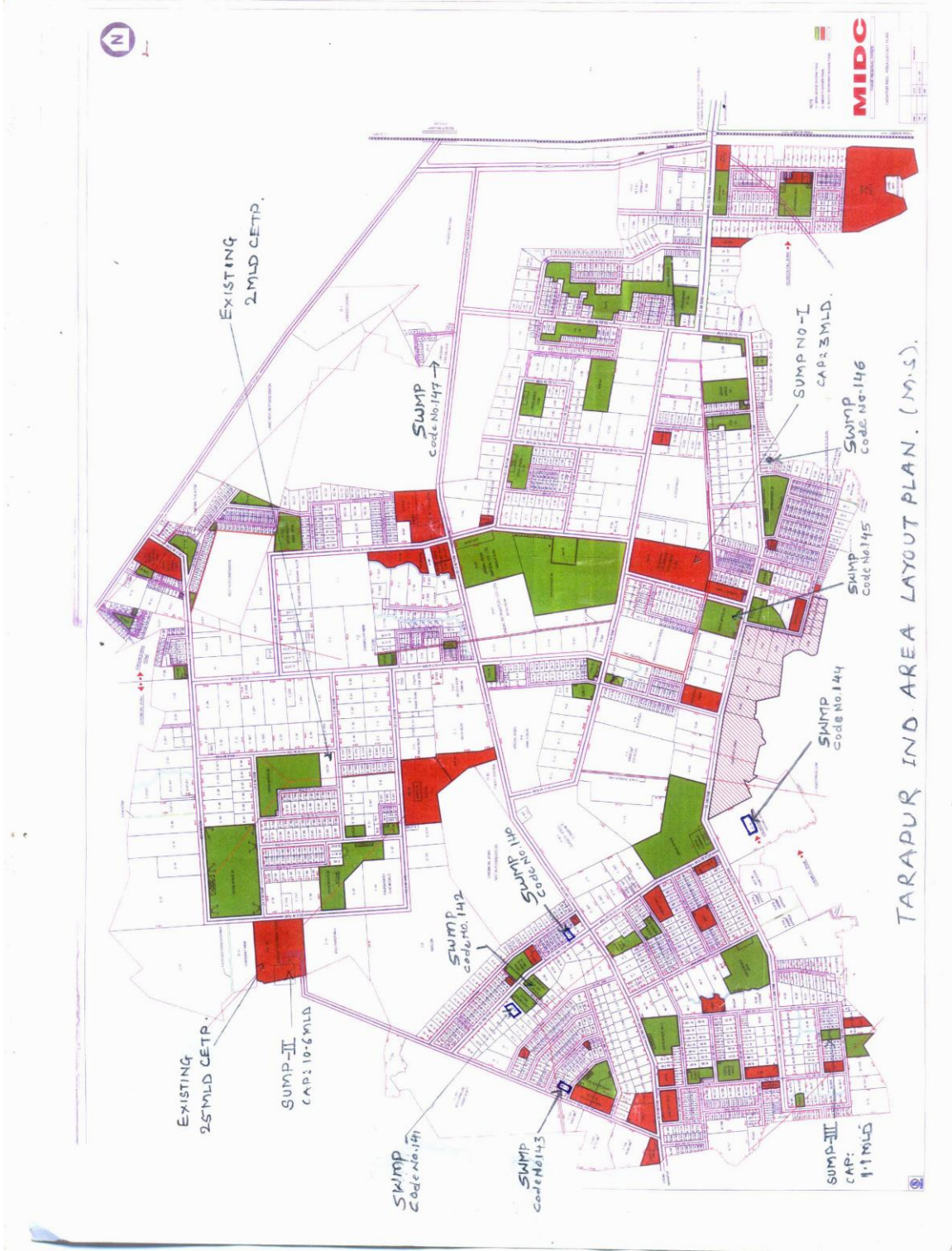

Map - I Tarapur MIDC Layout plan

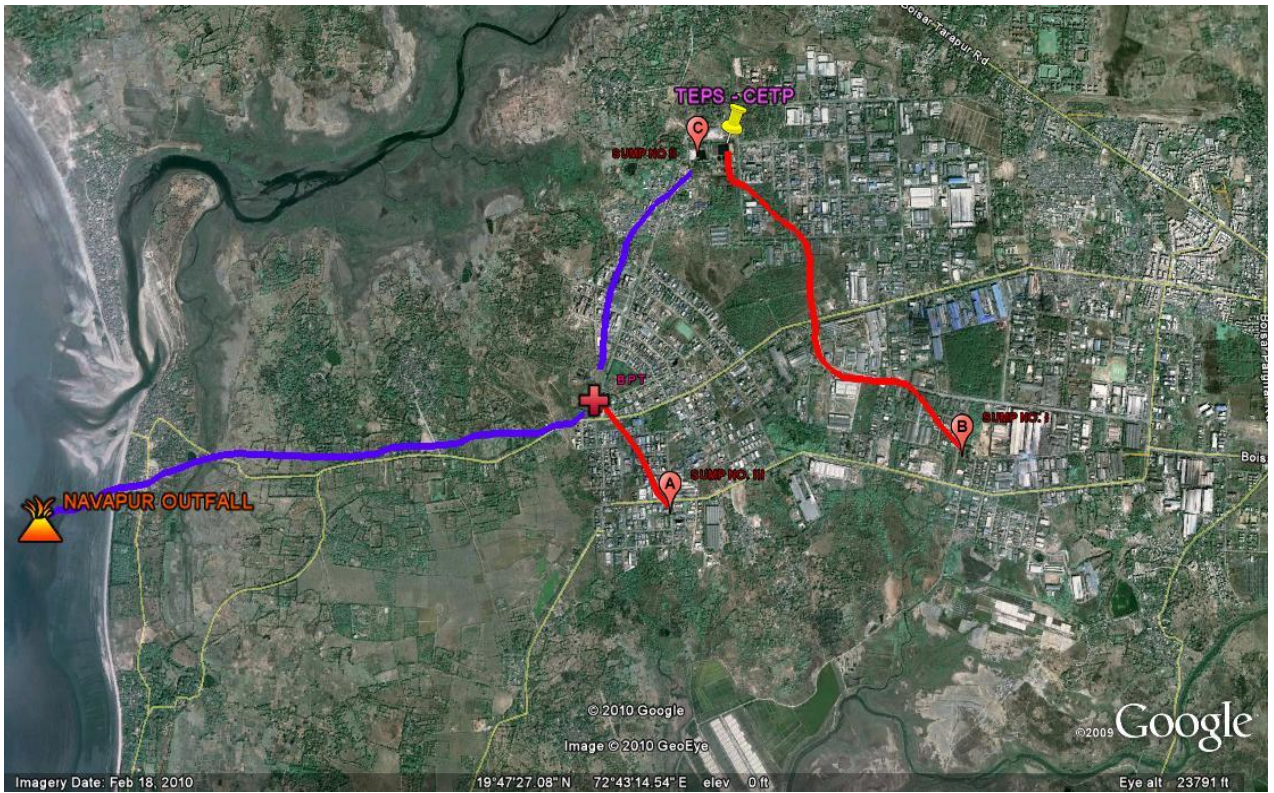

Map - II taken from Google.com

#### 1.4. CEPI Score (Air, Water, Land and Total)

- For Water Environment:

A1	A2	A	B1	B2	B3	B	C1	C2	C3	C	D
3.0	5.0	15.0	8.0	0.0	3.0	11.0	3.0	5.0	0.0	15.0	15.0

- Water CEPI = 56
- $A = A1 \times A2$ , A1 : Presence of Toxin, A2: Scale of Industrial Activities
- $B = B1 + B2 + B3$  B1 Pollution Concentratuion, B2 Impact on People , B3 Impact on Ecological Features .
- $C = C1 \times C2 + C3$ , Where C1 = Potential Affected Population C2= Level of Exposure, C3=Risk to Sensitive Receptor .
- D= Additional High Risk Element.
- Target to reduce A1,B1,C2 & D to reduce over all CEPI index.

- For Air Environment:

A <sub>1</sub>	A <sub>2</sub>	A	B <sub>1</sub>	B <sub>2</sub>	B <sub>3</sub>	B	C <sub>1</sub>	C <sub>2</sub>	C <sub>3</sub>	C	D
5.75	5.0	28.75	2.0	3.0	3.0	8.0	3.0	3.0	5.0	14.0	10.0

- Air CEPI = 60.75

- A = A<sub>1</sub> x A<sub>2</sub> , A<sub>1</sub> : Presence of Toxin, A<sub>2</sub>: Scale of Industrial Activities
- B = B<sub>1</sub>+B<sub>2</sub>+B<sub>3</sub> B<sub>1</sub> Pollution Concentration, B<sub>2</sub> Impact on People , B<sub>3</sub> Impact on Ecological Features .
- C = C<sub>1</sub> x C<sub>2</sub> +C<sub>3</sub> , Where C<sub>1</sub> = Potential Affected Population C<sub>2</sub>= Level of Exposure, C<sub>3</sub>=Risk to Sensitive Receptor .
- D= Additional High Risk Element.

- For Land Environment:

	A <sub>1</sub>	A <sub>2</sub>	A	B <sub>1</sub>	B <sub>2</sub>	B <sub>3</sub>	B	C <sub>1</sub>	C <sub>2</sub>	C <sub>3</sub>	C	D
Existing	3.0	5.0	15.0	7.75	3.0	3.0	13.75	5.0	1.5	0.0	7.5	15.0
After ST	2.5	5.0	12.5	7.0	3.0	3.0	13.00	5.0	1.5	0.0	7.5	15.0

- Land CEPI = 51.25

- A = A<sub>1</sub> x A<sub>2</sub> , A<sub>1</sub> : Presence of Toxin, A<sub>2</sub>: Scale of Industrial Activities
- B = B<sub>1</sub>+B<sub>2</sub>+B<sub>3</sub> B<sub>1</sub>: Pollution Concentration, B<sub>2</sub> Impact on People , B<sub>3</sub> Impact on Eco-geological Features .
- C = C<sub>1</sub> x C<sub>2</sub> +C<sub>3</sub> , Where C<sub>1</sub> = Potential Affected Population C<sub>2</sub>= Level of Exposure, C<sub>3</sub>=Risk to Sensitive Receptor .
- D= Additional High Risk Element.



**1.5. Total Population and sensitive receptors (hospitals, educational institutions, courts etc) Residing in the area comprising of geographical area of the cluster and its impact Zone (minimum 2 km)**

As of 2001 India census, Tarapur had a population of 7012. Males constitute 50% of the population and females 50%. Tarapur has an literacy rate of 91% for both males and females, much higher than the national average of 60%. In Tarapur, 11% of the population is under 6 years of age.

Total villages around Tarapur Industrial area namely Boisar, Salwad, Kumbhavali, Pasthan, Pam and Sarawali. Boisar is main residential area located within in 2 .0 km radius from MIDC Tarapur. There are 16 villages in and around Tarapur Industrial area come under radius of 5.0 km compromising total population 88399 as per year 2001 census. Details of population is given table 1.1

**Table 1.1**

**Population in surrounding at MIDC, Tarapur area (Year 2001)**

Sr. No	Village	Distance from MIDC	POPULATION		
			Ladies	Gents	Total
1	BOISAR	@ 500 meters	6356	8329	14685
2	SALWAD	@ 500 meters	3058	4829	7887
3	KUMBHAVALI	@ 500 meters	851	1232	2086
4	PASTHAL	@ 1 km	7551	8634	16185
5	PAM	@ 1.5 km	816	1093	1909
6	SARAWALI	@ 1 km	2483	3020	5503

**1.6. Eco-geological features Impact Zones (the area comprising of geographical area of the cluster and its impact zone (minimum 2 km)**

**1.6.1 Major Water Bodies (Rivers, Lakes, Ponds etc)**

There are no Rivers, lakes, ponds within the radius of 2.0 km. However, River surya is flowing within the 12 Km from industrial area which is main water source for operations of industrial activities.

**1.6.2 Ecological Parks, sanctuaries, flora and fauna or any eco sensitive zones.** There are no Ecological Parks, sanctuaries, flora and fauna or any eco sensitive zones from boundary of MIDC.

**1.7. Industry classification and distribution (no. of industries per 10 sq.km area or fraction)**

**1.7.1 Highly Polluting industries (17 categories)**

As per list of highly polluting industries as given by Central Pollution Control Board, there are 17 categories of industries listed, out of which the following industries have existed in Tarapur industrial area. The details of the same is given Table 1.2

**Table 1.2 Highly Polluting industries at Tarapur**

Sr. No.	Category of industry	Scale	No. of industries
1.	Dye and Dye intermediates	LSI/MSI/SSI	20
2.	Iron and Steel	LSI/MSI/SSI	12
3.	Pesticides	LSI/MSI	1
4.	Drugs and Pharmaceuticals	LSI/MSI/SSI	41
		<b>Total</b>	<b>74</b>

**1.7.2 Red category industries (54 categories)**

Red Category industries as per Ministry of environment forests are 54 categories. Out of which the following categories of industries are under operation in Tarapur Industrial area. The details of the same are given in Table1.3

**Table 1.3 Red Categories Industries in Tarapur**

Sr. No.	Category of industry	Scale	No. of industries
1.	Dye and Dye intermediates, Bulk drugs and pharmaceuticals	LSI/MSI/SSI	392
2.	Iron and Steel (Galvanizing and pickling)	LSI/MSI/SSI	26
3.	Pesticides	LSI/MSI/SSI	1
4.	Textiles	LSI/MSI/SSI	265
5.	Engineering	LSI(/MSI/SSI	138
		<b>Total</b>	<b>822</b>

### 1.7.3 Orange and Green Category industries

There are number of Green and orange category industries in Tarapur Industrial area. These are basically small scale industries generating small to nil quantity of effluent. Details of the same is given in Table 1.4

**Table 1.4 Orange and Green category Industries in Tarapur**

<b>Scale</b>	<b>Orange</b>	<b>Green</b>
LSI	04	03
MSI	08	15
SSI	65	527
<b>Total</b>	<b>77</b>	<b>501</b>

#### **1.7.4 Grossly Polluting industries**

There is no grossly polluting industry in MIDC Tarapur which is discharging treated/untreated effluent directly to River /creek. Industries located in MIDC Tarapur have their own effluent treatment facilities. Most of industries located in Tarapur industrial area have become members of TEPS CETP. Some of the small scale industries have yet to become member of TEPS CETP. Individual industries are treating effluent in their in house Effluent Treatment Plants. Treated effluent collected from individual industries will be further treated by TEPS CETP and finally discharged to MIDC sumps from where MIDC is pumping treated effluent/partially treated effluent to Navapur Creek. Some quantity of treated effluent is discharged to MIDC sump from where it will be destined to navapur creek.

## Chapter 2

### 2. WATER ENVIRONMENT

---

#### 2.1. Present status of water environment supported with minimum one year analytical data

##### 2.1.1. Water bodies/effluent receiving drains in the area important for water quality monitoring

###### Surface Water:

The important river flowing through the region are Surya. This river is important drinking water resources of the region. M.P.C. Board regularly monitors the water quality and the water quality is generally meeting the standards specified by the best uses in the particular stretches. The average water quality of these rivers is presented in Table 2.1

**Table 2.1 Surya River Quality Data**

Parameter	Surya River near Dhamni Dam	Surya River at Maswan	Surya River Station Pump
pH	7.7	10.73	7.86
Turbidity (NTU)	8.2	13.87	17.33
Conductivity puhos / cm.	143.3	199.33	193.08
Dissolved Oxygen mg / l	6.5	6.5	6.76
B.O.D. mg / l	3.8	4.3	4.3
C.O.D.	18.6	22.0	20.0
Nitrate – mg / l	0.24	0.43	0.253
Nitrate – mg / l	0.006	0.015	0.0068
Ammonia – N mg / l	0.08	0.094	1.782
Chlorides	5.52	8.74	9.82
Phosphate	0.3	0.45	0.25
Fecal Coliform /100 ml	27.6	78.75	31.16
Total Coliform (MPN)/100 ml	65.6	205.62	82.5
Colour	<10Hazen unit		<10Hazen unit

## Ground water

MPCB is monitoring Ground water quality in and around Industrial area. MPCB has identified sample bore wells and regularly draws samples for knowing the quality of water. Ground water Quality analytical data is given Table 2.2

**Table 2.2 Ground Water Quality Analysis Report from MIDC Tarapur Area (2008-2010)**

Name of the monitoring station	(2008-2009)								(2009-2010)							
	pH	CaCo3	Cl	DO	BOD	COD	SO4	Nitrate	PH	Caco3	Cl	DO	NO3	SO4	BOD	COD
	Avg	Avg	Avg	Avg	Avg	Avg	Avg	Avg	Avg	Avg	Avg	Avg	Avg	Avg	Avg	Avg
1) Bore well at M/s. Tata steel s-76	7.5	444	151	7	4.1	26	91	0.4	7.4	476	356	5.9	3.16	62.59	22	16
2) Bore well at M/s Precise	7.7	535	204	7.2	3.5	36	118	7.18	7.85	626	244	5.1	0.11	0.18	24	13
3) Bore well at dhodi pooja	7.5	429	139	7	4.2	26	92.2	0.42	7.41	342	299	7.8	0.01	0.07	26	12
4) Bore well at chandnika Magar	7.9	493	195	7.1	4.6	22	113	7.58	7.9	725	475	5.75	2.24	26.65	5.5	21
5) Bore well at chikuwadi	7.5	445	147	6.8	6.7	38	92.4	0.47	7.58	350	94	5.5	0.01	30.09	26	11
6) Bore well at Lauaraj paiwadi	7.2	575	179	6.2	4	32	91.2	7.8	7.6	723	303	5.8	18.1	93.05	5.6	24

**All values are in mg/l. except pH.**

## Coastal water

Thane region is covered by Arabian Sea on the western side, and therefore, the region is dominated by a long coastline and associated coastal features such as creeks, small creek lets etc. The effluent generated from the Industrial area located in the region along with industrial effluent is finally disposed in the creeks. M.P.C. Board regularly monitors the water quality at the above important creeks. MPCB has identified the following creeks to check the quality of water.

1. Navapur sea
2. Kharekuram murbe creek
3. Dandi creek
4. Sarvalli creek

Quality data analyzed by MPCB for the last year is given in Table in 2.3

**Table: 2.3 Coastal water quality**

**Analysis results of Final Outlet at Navapur Sea.**

Year	pH	SS	BOD	COD
2004-2005	6.7	201	340	1613
2005-2006	6.83	120	539	1338
2006-2007	7.41	169	478	1226
2007-2008	8.18	178	408	1169
2008-2009	7.55	130	205	598

**All values are in mg/l. except pH.**

**Analysis results of Sea water at Navapur.**

Year	pH	SS	BOD	COD
2005-2006	7.79	43.78	12	148
2006-2007	7.25	90.00	13	182
2007-2008	7.85	94.44	14	178
2008-2009	8.04	47.5	10	183

**All values are in mg/l. except pH.**

**Overall quality of Sea / Creek Water (Data - 2009-10)**

	pH	COD	BOD
Navapur	7.9	156	16
Saravali	8.3	125	14
murbe Kharekhuram	7.6	112	14
Dandi	7.9	152	16

**All values are in mg/l. except pH.**

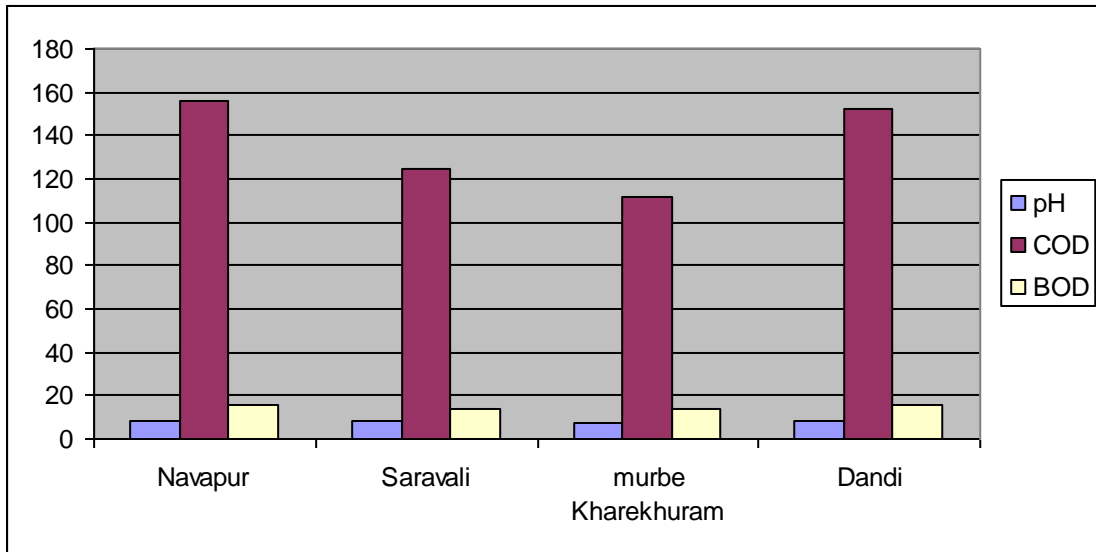

**Graphical representation of Sea / Creek Water Quality**



**2.1.2. Present levels of pollutants in water bodies/effluent receiving drains/ground water (routine parameters, special parameters and water toxics relevant to the area in three categories- known carcinogens, probable carcinogens and other toxics)**

Data of probable carcinogens and toxics not available. However, the industrial area accommodates major chemical units including bulk drugs, dyes & intermediates and therefore such studies are proposed as part of action plan.

**2.1.3. Predominant sources contributing to various pollutants**

Maharashtra Industrial Development Corporation (MIDC) Tarapur is running 59 kilometers of effluent carrying pipeline through out industrial area to dispose treated/partially treated effluent to Arabian Sea at Navapur. It was observed / reported that there were leakage in effluent carrying pipeline which might be leading to introducing the pollutants to ground water. These leakage were arrested by MIDC as and when arised.

Tarapur industrial area is surrounded by small towns / villages consuming water for domestic purposes. It is observed that there is no treatment facility to treat domestic effluents to the standards. All domestic effluent or sewerage is currently being discharged to Arabian Sea through Nalla.

**2.2. Sources of water pollution**

**2.2.1. Industrial**

There are 1182 nos. of industries which are currently operational generating 33 MLD of effluent which will initially be treated by individual industries and then CETP. Currently, a 25 MLD capacity Tarapur Environmental Protection Society TEPS-CETP is under operation and at average COD of 45.6 Tones per day is being received, out of which 37.0 tons/day is being treated resulted in 8.8 tons of COD per day is discharged to Arabian sea. Details of the same are given in Table. 2.4

**Table 2.4 Amount of COD Load removed by 25 MLD TEPS-CETP Tarapur**

Month	Raw COD (T/M)	Treated effluent COD (T/M)	COD Removed (T/M)
Jan.-2010	1372.690	282.3	1090.3
Feb-2010	1372.7	282.4	1090.4
March-2010	1356.311	247.45	1108.8
April-2010	1389.1	241.1	1147.9
May-2010	1368.5	253.7	1114.8
<b>Average (MT/D)</b>	<b>45.6</b>	<b>8.8</b>	<b>37.0</b>

**These values are monitor by TEPS-CETP**

Apart from above, 4 MLD of untreated effluent generated from N zone is collected into Sump No. 3 of MIDC. Currently, the average COD of this untreated effluent from Sump No. 3 is 3760 mg/l amounting to 15.04 tons per day is being discharged to Arabian sea.

Amount of COD load disposed to Navapur Creek is as below :

- |                          |           |                            |
|--------------------------|-----------|----------------------------|
| i) Through 25 MLD CETP   | :-        | 8.5 Ton/Day (Avg.)         |
| ii) Through Sump No. III | :-        | 15 Ton/Day (Avg.)          |
| <b>Total COD</b>         | <b>:-</b> | <b>23.5 Ton/Day (Avg.)</b> |

Therefore, amount of COD disposed to Navapur Creek considering the leakages etc. is say 25 Ton/Day.

**After the implementation of Action plan programme the total COD disposed to Navapur Creek is calculated as below :-**

- 1) Considering the average flow-rate 26 MLD and treated effluent quality 250 mg/l is calculated to be 6.5 Ton/Day

- 2) After connection of transfer pipeline from Sump NO. III to CETP, the entire effluent will be treated in CETP, so the amount of COD Load is calculated to be 1 Ton/Day.
- 3) The TEPS-CETP has proposed additional 12 MLD CETP to cater the additional hydraulic load generated from "N" zone sump and part of effluent collected at sump no.1. The TEPS-CETP has got approval from NEERI Nagpur.
- 4) Therefore total COD Load disposed at Navapur Sea will be 7.5 Ton/Day.

**Present amount of COD disposed to Navapur Creek : 25 Ton/Day.**

**After implementation of Action Plan**

**Amount of COD load disposed to Navapur Creek : 7.5 Ton/Day.**

### **2.2.2. Domestic**

MIDC is supplying 22 MLD of water domestic purposes around villages of Tarapur industrial area which will generate around 20.0 MLD of sewage. Currently, there is no sewage Treatment Plant existed to treat Sewage generated. Untreated sewerage is being discharged to Arabian sea through various Nalla.

### **2.2.3. Others (Agricultural runoff, leachate from MSW dump, illegal dump site etc.,)**

Tarapur Industrial is surrounded villages within 5.0 km region, are cultivating vegetation. No data on Agricultural runoff is available with this board. This requires a study to understand.

The hazardous waste was dumped by the factories located in MIDC Tarapur Industrial Area at various locations such as K-Zone, 70 Bungalow area and many other places prior to 2005 has been collected and stored in secured engineering land fill site at K-Zone in 2006. The total quantum of waste kept at this secured land fill is 1,50,000 MT. costing 5.0 cr.

Currently, there are no illegal dump sites in industrial area. All industries have become members of Common Hazardous Waste Treatment Storage Disposal facility (CHWTSDf) located in Talaja. Hazardous wastes generated from industries are being transported for disposing to TSDf an authorized facility to handle hazardous waste.

There are observations that some of the industries are dumping Hazardous waste illegally and Board has issued showcase notices and made errant industries to lift dumped material to CHWTSDf and are fine with penalties.

Apart from above, Population is residing in and around industrial area generating 10-12 MT of Municipal solid waste per day which is illegally dumped at Suttar bungalow adjacent to Tarapur MIDC. Leachate generate from illegal municipal solid wastes are ultimately will be destined to ground.

A view of the illegal dump of hazardous wastes by industries before and after action taken is shown in following photographs.

**Before year 2005**



**Illegal dump site before Encapsulation**



**Secured landfill site after encapsulation**



**Secured landfill site after encapsulation**



**Secured landfill site after encapsulation**



**Secured landfill site after encapsulation**

**Present dump of MSW at Suttar Bungalow located adjacent to MIDC Tarapur**



**Illegal MSW dump site near Sattur bungalow adjacent to MIDC Tarapur**





#### **2.2.4. Impact on surrounding area (outside the CEPI Area) on the water courses/drainage system of the area under consideration**

Water course outside industrial area is being Surya river which is regularly monitored by MPCB. Data is suggesting that river is not polluted and water is being utilized by Industrial area for its operations and also being utilized for domestic purposes by nearby villages. However, drainage systems of surrounding areas needs study as no treatment facility to treat sewerage generated

#### **2.3. Details of Water Polluting Industries in the area/cluster**

There are 1150 nos. of industries being operated which include Red, orange and Green category of industries. Industries

There are highly polluting industries located as per Table 1.2. All highly polluted industries are having Effluent Treatment facility to treat effluents generated. Industries located in N zone are generating around 4 MLD of effluents which

#### **2.4. Effluent Disposal Methods-Recipient water bodies etc.,**

Industries treat effluents in house and will be disposed to TEPS CETP for further treatment. The treated effluent generated from all industries is collected through underground drainage system in three different sumps provided by MIDC. Details of sumps are as below :

- |                 |    |                               |
|-----------------|----|-------------------------------|
| 1) Sump No. I   | :- | 3000 M <sup>3</sup> Capacity  |
| 2) Sump No. II  | :- | 10650 M <sup>3</sup> Capacity |
| 3) Sump No. III | :- | 1180 M <sup>3</sup> Capacity  |

Thus the effluent collected at sump No. I is being pumped to 25 MLD TEPS-CETP and the effluent generated at Sump No. II catchment area is being treated at 25 MLD capacity. The primary treated effluent collected at Sump No. III is at present not connected to 25 MLD CETP. Therefore the

primary treated effluent is being directly pumped to BPT-Tank. The treated effluent from CETP is collected at Sump No. II and from there it is being pumped to dispose it into the sea at Navapur which is 4 km away from Industrial area. The schematic diagram of collection and disposal of effluent is shown below :

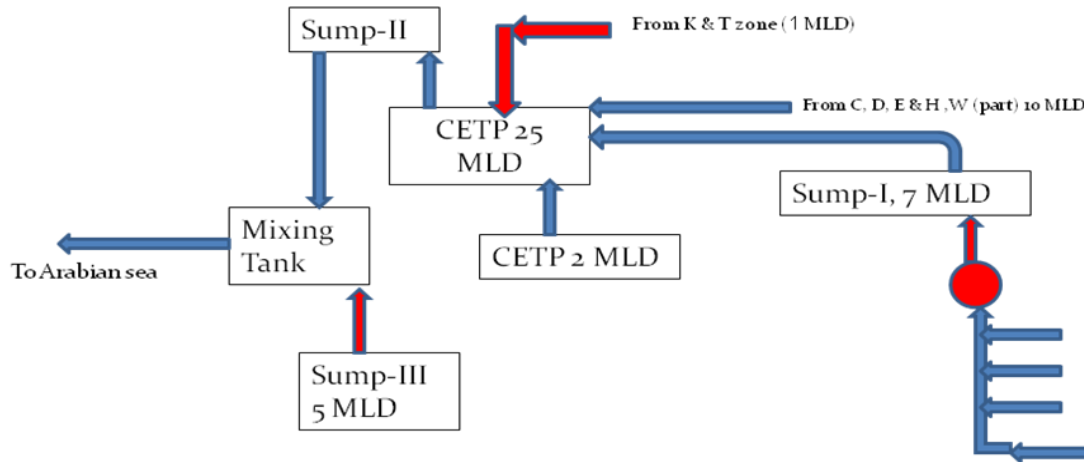

**2.5. Quantification of wastewater pollution load and relative contribution by different sources viz., industrial/domestic**

**Capacity of TEPS-CETP 25 MLD**

**Average flow rate to TEPS-CETP 26 MLD**

**Total quantum of effluent generated in MIDC Tarapur Industrial area is calculated to 33 MLD. (Based on Sump Capacity and effluent pumping capacity located at Sumps)**

**Amount of COD Load removed by 25 MLD TEPS-CETP Tarapur**

Month	Raw COD (T/M)	Treated COD (T/M)	COD Removed (T/M)
Jan.-2010	1372.690	282.3	1090.3
Feb-2010	1372.7	282.4	1090.4
March-2010	1356.311	247.45	1108.8
April-2010	1389.1	241.1	1147.9
May-2010	1368.5	253.7	1114.8
<b>Average (MT/D)</b>	<b>45.6</b>	<b>8.8</b>	<b>37.0</b>

**These values are monitor by TEPS-CETP**

**I) Amount of COD Load receiving at Sump No. III**

- a) From analysis reports the average value of COD receiving at **Sump NO. III is 3760 mg/l.**
- b) The average quantity of effluent received at Sump No. III reported by Dy. Engineer, MIDC Tarapur is **4 MLD.**
- c) Amount of COD at Sump No. III is **15.04 Ton/Day.**
- d) Amount of COD load disposed to Navapur Creek is as below :
  - iii) Through 25 MLD CETP :- 8.5 Ton/Day (Avg.)
  - iv) Through Sump No. III :- 15 Ton/Day (Avg.)
  - Total COD :- 23.5 Ton/Day (Avg.)**

Therefore, amount of COD disposed to Navapur Creek considering the leakages etc. is say 25 Ton/Day.

**2.6. Action plan for compliance and control of pollution**

**2.6.1. Existing infrastructure facilities-water quality monitoring network, ETPs, CETPs, Sewerage Treatment Plant of industry (STPs), surface drainage system, effluent conveyance channels/outfalls etc.,**

**Water Quality monitoring Network-**

Monitoring of water and waste water quality is carried out by MPCB regularly (Monthly, Quarterly, half yearly and yearly). This monitoring is headed by Sub Regional Officer with the help of field officers of MPCB.

1. Joint vigilance sample (JVS) is collected monthly, quarterly as per Board guidelines from industries and will be analyzed by MPCB laboratory.

2. Effluent receiving receptors are being monitored by MPCB under State water monitoring project (SWMP). Samples will be drawn from the following sources

1. BPT Navapur ,
2. Navapur Sea,
3. Dandi Creek,
4. Kharekuram murbe creek,
5. sarovalle creek,
6. Near MIDC sump no. 1,
7. Sump no.2
8. Sump No. 3

3. Ground water is monitored Quarterly by MPCB at following locations

1. Bore well at M/s Tata steel
2. Bore well at M/s precise alloy
3. Borewell at Dondipuja
4. Borewell at Chandrika nagar
5. Borewell at Chikkujiwadi
6. Borewell at lalawajpe wadi

(Monitoring location are shown in the Map.)

### **Common Effluent Treatment Plant**

#### **Details of Existing CETP**

The present 25 MLD CETP has been designed based on treatability study conducted by TEPS for the composite effluent of the industrial area prior to setting up of the plant.. The design and observed parameters are as below. The table also highlights the parameters of treated effluent as imposed by MPCB (Maharashtra Pollution Control Board) under Section 25 of Water (Prevention & Control of Pollution) Act-1974.

## Design and Operating Parameters of 25 MLD CETP

PARAMETER	UOM	DESIGN VALUES	CURRENT OBSERVED VALUES	MPCB CONSENT VALUES
FLOW	MLD	25	28-34	25
pH	--	6.5 to 9.3	6.5 to 9.3	5.5 TO 9
TSS	mg/lit	1000	600	Not to Exceed <b>100</b>
COD	mg/lit	3500	1800	Not to Exceed <b>250</b>
BOD	mg/lit	1500	1000	Not to Exceed <b>100</b>
Oil & Grease	mg/lit	50	30	Not to Exceed <b>20</b>
TDS	mg/lit	7000	5500 - 6500	Not specified

### Description of Present CETP of 25 MLD

The present set up is constructed on plot AM 29. The construction of 20 MLD started in 2005 and was completed in 2008 and that of 5 MLD started in May 2009 and was completed in October 2009.

The treatment scheme consists of Activated Sludge Process and has Primary, Secondary and Tertiary treatment. The design is based on treatability study carried out prior to implementation of 25 MLD project.

#### 1. Receiving and Pumping

The effluent is received in a receiving sump of 1000 m<sup>3</sup> capacity by gravity and is subjected to suspended matter and Oil and Grease removal. A pump house with 4 pumps is provided to pump the effluent to equalization tanks.

#### 2. Equalization

The effluent is then received in four equalization tanks of 3000 M<sup>3</sup> each. Each tank is provided with four floating surface aerators of 15 HP each. A set of pumps and a non contact Magnetic flow meter has been installed to measure flow of neutralized effluent pumped to flash mixer for further treatment.

### **3. Flash Mixing**

After equalization effluent is received in two flash mixers and process of flocculation is carried out by dosing flocculent viz. Alum.

### **4. Primary Treatment.**

The flocculation is also carried out in flocculation chambers of two Primary Flocculators. The flocs are settled in settling chambers by using a scarp mechanism and the overflow is taken to conventional aeration tanks for biological treatment.

### **5. Biological Treatment**

The overflow from primary is taken to four Bio Reactors viz. A, B, C and D. Tanks A, B and C have fine bubble aeration system with pipe diffusers with EPDM membrane. (Currently under rectification). Tank D has pipe diffusers with fine bubble pores and silicone membrane.

### **6. Secondary Clarification and Oxidation.**

After bio treatment, the bio sludge is settled in two clarifiers and overflow is taken to oxidation tank for oxidation by using Hypo Chloride solution. . Oxidation tank has ceramic diffusers for mixing. Air supply from blowers of aeration tank is provided.

### **7. Sludge handling**

Sludge from Primary and secondary treatment is collected in a circular sludge holding tank and is subjected to water removal in centrifugal decanters. The sludge disposal is carried out by collection and conveying to solar beds which has leachate collection and solar drying arrangement. The semi dried sludge is transported to CHWTSDF (Common Hazardous Waste Treatment and Safe Disposal Facility) site of Mumbai Waste Management, Taloja near Mumbai.

As seen from table on page 8 the current observed values are lower than design except the flow. However once effluent of sump 3 is received at CETP the values may be different. Please see the details of basis of design for this on page 38.

The plant is operated in three shifts under O & M contract and the results are analyzed in the laboratory regularly.

The plant has a standby DG set of 650 KVA and a new DG set of same capacity is under installation.

The operating expenses of the plant are met through treatment charges levied by TEPS to all its members and it is presently based on water consumption.

TEPS has observed a few areas of improvement in existing plant and is in the process of implementing the same.

**25 MLD TREATMENT PLANT OF CETP TARAPUR**  
**EXISTING UNITS / EQUIPMENT LIST**

<b>UNITS</b>			
<b>Sr. No.</b>	<b>EQUIPMENT DESCRIPTION</b>	<b>SPECIFICATION</b>	<b>QTY.</b>
1	Receiving sump with pump room	15m dia x 3 m SWD 6m x 5 m pump room	1
2	Oil & grease traps	10m x 2m x 2m SWD	2
3	Screen Chamber	5m x 2m x 2m SWD	2
4	Equalization tanks	32m x 32m x 3m SWD	4
5	Flash Mixers	3m dia x 2m SWD	2
6	Primary Cariflocculators	27m Dia x 2.5m SWD	2
7	Aeration tanks	70m x 36.5m x 4.8 m SWD	4
8	Secondary Clarifiers	31.5m dia x 2.5 m SWD	2
9	Oxidation cum Treated effluent hold tank	25m x 12.5m x 3.2m ht.	1
10	Chemical house	10m x 10m	1
11	Testing Laboratory	10m x 10m	1
12	Main Office	10m x 10m	1
13	MCC room	10m x 10m	1
14	Lime Slurry preparation tanks	18m <sup>3</sup> each	3
15	Nutrient solution preparation tanks	10m <sup>3</sup> each	2
16	Flocculent solution preparation tanks	10m <sup>3</sup> each	2
17	Shed for centrifuge and solution reparation shed	78 m <sup>2</sup> +122 m <sup>2</sup>	1



18	Sludge holding tank	200 m <sup>3</sup>	1
----	---------------------	--------------------	---

**EQUIPMENTS**

Sr. No.	EQUIPMENT DESCRIPTION	SPECIFICATION	QTY.
1	Receiving sump pumps	450 m <sup>3</sup> /hr	4
2	Belt type oil and Grease trap	60 LPH	1
3	Screens for screen chamber	Site fabricated	2
4	Floating aerator for equalization tanks	15 HP	16
5	Effluent transfer pumps	350 m <sup>3</sup> /hr	6
6	Flash Mixer agitators	2 HP	2
7	Flocculator mixer	3HP	4
	Primary Cariflocculator mechanism	27m dia x 2.5m SWD	2
8	Air blowers for aeration tank	3300 m <sup>3</sup> /hr @ 6 MWC	4
	Air blowers for aeration tank	1750 m <sup>3</sup> /hr @ 6 MWC	10
9	Diffused aeration system for aeration tank	1100 X 1 M long per tank X 3 1118 x2 M long X 1	4418 ( 3300 +1118)
10	Secondary Clarifier mechanism	31.5m dia x 2.5 m SWD	2
11	Sludge recycle pumps	280m <sup>3</sup> /hr @ 5 MWC	3
12	Agitator for sludge tank	10 HP	1
13	Sludge feed pumps	23m <sup>3</sup> /hr - 2 no. , 30m <sup>3</sup> /hr - 1no.	3
14	Agitator for lime dosing tank	2 HP	3
15	Lime dosing pumps	2 HP	2
16	Agitator for nutrient dosing	2 HP	2

	tank		
17	Nutrient dosing tank	2 HP	2
18	Flocculent tank agitator	2 HP	2
19	Flocculants dosing pumps	2 HP	2
20	Poly solution tank for decanter	2 m3	2
21	Poly dosing pump for decanter	1 HP each	4
22	Poly tank agitator	1 HP each	2
23	Decanters	23 m3/hr - 2 nos.	3
		30m3/hr - 1 no.	
24	Hypo solution tank	10m3	2
25	Sintered diffusers for oxidation tank	Disc Type	lot
26	Filter feed pumps	350 m3/hr @ 20 m WC	4
27	Pressure sand filters	260 m3/hr	4
28	Activated carbon filters	260 m3/hr	4

**Aerial View of 25 MLD TEPS-CETP under operation is shown**



**Aerial View of 25 MLD TEPS-CETP under operation is shown**



**A View of Activated sludge process under operation**



**Aerial View of secondary clarifier Tank**



## Effluent Drainage system

Tarapur Industrial Area is having a wide 59 kilometers of effluent carrying piping network to transfer effluent. The treated effluent generated from all industries is collected through underground drainage system in three different sumps provided by MIDC. Details of sumps are as below :

- 1) Sump No. I :- 3000 M<sup>3</sup> Capacity
- 2) Sump No. II :- 10650 M<sup>3</sup> Capacity
- 3) Sump No. III :- 1180 M<sup>3</sup> Capacity

Thus the effluent collected at sump No. I is being pumped to 25 MLD TEPS-CETP and the effluent generated at Sump No. II catchment area is being treated at 25 MLD capacity. The primary treated effluent collected at Sump No. III is at present not connected to 25 MLD CETP. Therefore the primary treated effluent is being directly pumped to BPT-Tank. The treated effluent from CETP is collected at Sump No. II and from there it is being pumped to dispose it into the sea at Navapur which is 4 km away from Industrial area. The schematic diagram of collection and disposal of effluent is shown below :

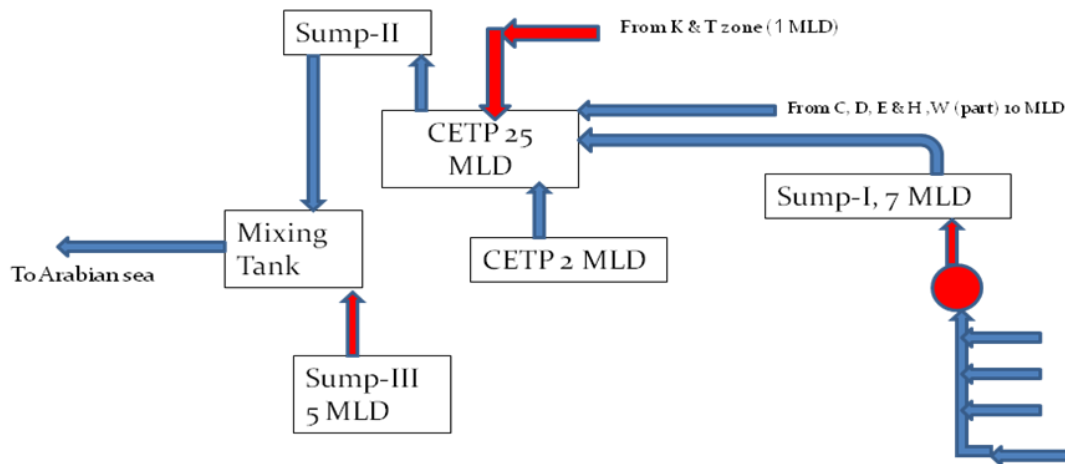

Maharashtra Industrial Development Corporation is having 59 kilometers of wide effluent carrying pipeline which is of RCC MOC is being maintained by MIDC. Due to leakages in existing pipe lines, MIDC is replacing RCC pipe lines with HDPE pipelines. This replacement of pipeline is around 27 kilometers is completed. And the work of replacement of HDP pipeline 6 km. costing Rs. 110 Lakhs by 2010-2011, replacement of another 9 km. costing Rs. 1800 lakhs by 2011-2012 is planned Phase wise by the MIDC authority.

### **2.6.2 Pollution control measures installed by Industries**

#### **Effluent Treatment Plants**

Industries located in Tarapur have been classified into Red, Orange & Green under large, medium and small scale industries. Industries which will come under purview of Red category are all having Effluent Treatment Plants. Effluent Treatment Plants which are under operation in industrial areas have been designed based on the effluent characteristics. The major treatment units consisting of Primary treatment, Secondary and Tertiary Treatment.

Primary treatment units are combination of Bar screens, Equalization Tanks, Neutralization Tanks, Flash mixers, Flocculators and Primary Settling Tanks. These Primary Treatment Units are designed to remove Suspended solids present in influent.

Secondary Treatment units consisting of Activated Sludge process combination of Aeration Tanks and Clarifiers. Oxygen required for Aeration process is supplied by various mechanical aeration systems viz. Surface Aerators, Fixed Aerators, Diffused Aerators etc., Secondary treatment unit operations are aimed to remove organic matter present in effluent .

Tertiary Treatment units are majorly Sand filters and Carbon filters. In some cases, Tertiary Treatment unit consisting of Reverse Osmosis followed by Multifactor Evaporators and dryers.



**Some of the Effluent Treatment Plants aerial views are shown below**



**Aerial view of Full fledged ETP under operation by one of bulk drug industry from  
Tarapur**



**Aerial view of Full fledged ETP under operation by one of bulk drug industry from  
Tarapur**

### 2.6.3 Technological intervention

#### 2.6.3.1 Inventorisation of prominent industries with technological gaps

Tarapur industrial area is having various categories of industries. Depending upon manufacturing activity major category of industries are as under :-

1) Chemical (Bulk Drug / Dyes & Dye Intermediates / Pharmaceutical etc.)	:	392 Nos.
2) Textile	:	265 Nos.
3) Engineering	:	138 Nos.
4) Steel Plants (Galvanizing / Pickling)	:	26 Nos.
5) Food	:	21 Nos.
6) Paper & Packing	:	66 Nos.
7) Others	:	273 Nos.
<b>Total</b>		<b>1182 Nos.</b>

It is observed that major industries are having full fledged Effluent Treatment Plants consisting of Primary, Secondary and Tertiary treatment. Industries which will come under Medium and small scale industries are having improper Effluent Treatment facilities due to non feasibility of affording the capital and running cost. It is also observed that industries are not implementing the segregation methods to ensure better treatment of effluents.

Due to improper treatment facilities, Effluent discharged by individual industries is becoming complex to treat further by CETP. It is essential to ensure that all individual industries are putting up proper effluent Treatment facilities

#### 2.6.3.2 Identification of low cost and advanced cleaner technology for pollution control

There are very limited proven no low cost advanced cleaner technology to treat complex effluents generated from various types of industries. However, several industry have taken in plant majors including clean technologies intervention and reduction the effluent quantity and strength. Some of the examples are

-  RO Plant: - The following plants have provided advanced treatment technology such RO for reuse of waste water.

- M/s JSW Steel Ltd.,Plot No. B-6, MIDC, Tarapur, Boisar, Tal : Palghar, Dist : Thane - 401506, have provided RO of capacity 300 CMD.
- M/s. Sunway Textile Ltd, Plot No.G-21,have provided RO of capacity 3 KL / Day
- ✚ Caustic Recovery Plant :- the following plants have provided the caustic recovery plant
  - M/s.Mudra lifestyle limited, Plot No. D-1, MIDC,Tarapur, Boisar, Tal.Palghar, Dist :-Thane- 401506, have provided caustic recovery plant of capacity 10 Kl/hr.
  - M/s.Bombay Rayon Fashion Ltd. Plot No C-6 & C-7 MIDC, Tarapur, Taluka-Palghar, Dist- Thane., have provided caustic recovery plant of capacity 24 Kl/hr.
- ✚ Multi Effective Operator
  - M/s. Nipur Chemicals, Plot No. D-17, MIDC,Tarapur, Boisar, Tal.Palghar, Dist :-Thane- 401506, have provided multi effective operator for the concentration of rich stream generated from H-Acid manufacturing plant.
- ✚ Waste Pickle Recovery
  - M/s. Indorex Global Pvt Ltd, Plot No. B-11, MIDC,Tarapur, Boisar, Tal.Palghar, Dist :-Thane- 401506, have provided acid recovery plant of capacity 4.5Kl/Hr. The waste pickle from M/s.TATA Steel Ltd and M/s.JSW Ltd is treated at this plant.
- ✚ Recovery of Ammonium Sulphate
  - M/s. Arti Drugs Ltd, Plot No. N-198, MIDC,Tarapur, Boisar, Tal.Palghar, Dist :- Thane- 401506. This industry has developed new technology for the recovery of ammonium sulphate 2000 Mt / month by unit operation like evaporation, crystallization. Earlier the same was treated in their ETP.
  - Camlin Fine Chemicals. Ltd., Plot No. D, MIDC Tarapur has proposed segregation of high COD.
  - M/s. Arti Industries Ltd., E-50, has installed zero discharge plant such as incineration high COD.

#### 2.6.4 Infrastructure Renewal

##### 25 MLD Treatment Plant of CETP Tarapur Existing Units / Equipments list.

Sr. No.	EQUIPMENT DESCRIPTION	SPECIFICATION	QTY.
1	Receiving sump with pump room	15m dia x 3 m SWD 6m x 5 m pump room	1
2	Oil & grease traps	10m x 2m x 2m SWD	2
3	Screen Chamber	5m x 2m x 2m SWD	2
4	Equalization tanks	32m x 32m x 3m SWD	4
5	Flash Mixers	3m dia x 2m SWD	2
6	Primary Carifloculators	27m Dia x 2.5m SWD	2
7	Aeration tanks	70mx36.5mx4.8 m SWD	4
8	Secondary Clarifiers	31.5m dia x 2.5 m SWD	2
9	Oxidation cum Treated effluent hold tank	25m x 2.5m x 3.2m ht.	1
10	Chemical house	10m x 10m	1
11	Testing Laboratory	10m x 10m	1
12	Main Office	10m x 10m	1
13	MCC room	10m x 10m	1
14	Lime Slurry preparation tanks	18m <sup>3</sup> each	3
15	Nutrient solution preparation tanks	10m <sup>3</sup> each	2
16	Flocculent solution preparation tanks	10m <sup>3</sup> each	2
17	Shed for centrifuge and solution reparation shed	78 m <sup>2</sup> + 122 m <sup>2</sup>	1
18	Sludge holding tank	200 m <sup>3</sup>	1

#### 2.6.4.1 Details of existing infrastructural facilities CETP

<b>EQUIPMENTS</b>			
<b>Sr. No.</b>	<b>EQUIPMENT DESCRIPTION</b>	<b>SPECIFICATION</b>	<b>QTY.</b>
1	Receiving sump pumps	450 m <sup>3</sup> /hr	4
2	Belt type oil and Grease trap	60 LPH	1
3	Screens for screen chamber	Site fabricated	2
4	Floating aerator for equalization tanks	15 HP	16
5	Effluent transfer pumps	350 m <sup>3</sup> /hr	6
6	Flash Mixer agitators	2 HP	2
7	Flocculator mixer	3HP	4
	Primary Cariflocculator mechanism	27m dia x 2.5m SWD	2
8	Air blowers for aeration tank	3300 m <sup>3</sup> /hr @ 6 MWC	4
	Air blowers for aeration tank	1750 m <sup>3</sup> /hr @ 6 MWC	10
9	Diffused aeration system for aeration tank	1100 X 1 M long per tank X 3 1118 x2 M long X 1	4418 ( 3300 +1118)
10	Secondary Clarifier mechanism	31.5m dia x 2.5 m SWD	2
11	Sludge recycle pumps	280m <sup>3</sup> /hr @ 5 MWC	3
12	Agitator for sludge tank	10 HP	1
13	Sludge feed pumps	23m <sup>3</sup> /hr - 2 no. , 30m <sup>3</sup> /hr - 1no.	3
14	Agitator for lime dosing tank	2 HP	3
15	Lime dosing pumps	2 HP	2
16	Agitator for nutrient dosing tank	2 HP	2

17	Nutrient dosing tank	2 HP	2
18	Flocculent tank agitator	2 HP	2
19	Flocculants dosing pumps	2 HP	2
20	Poly solution tank for decanter	2 m3	2
21	Poly dosing pump for decanter	1 HP each	4
22	Poly tank agitator	1 HP each	2
23	Decanters	23 m3/hr - 2 nos.	3
		30m3/hr - 1 no.	
24	Hypo solution tank	10m3	2
25	Sintered diffusers for oxidation tank	Disc Type	lot
26	Filter feed pumps	350 m3/hr @ 20 m WC	4
27	Pressure sand filters	260 m3/hr	4
28	Activated carbon filters	260 m3/hr	4

#### 2.6.4.2 Need of up gradation of existing facilities

Due to large no. of chemical, textile and engineering industries total effluent quantity generated from the industries is 33 MLD. All large and medium scale industries have provided primary / secondary / tertiary effluent treatment plant. However, due to constraint of techno economically viability of the effluent treatment plant, small scale industries has provided only primary treatment facility. Therefore, the first CETP of 1 MLD capacity was constructed in the year 1994 in Maharashtra. Now due to increase in no. of industries and subsequently increase of effluent quantity, Tarapur Environmental Protection Society has constructed and commissioned 20 MLD CETP capacity in the year March-2007. However, this CETP was not sufficient to treat the all the effluent therefore again it was expanded for the 5 MLD capacity in the year 2009.

- 1) In spite of expansion of CETP to 25 MLD till it is inadequate to take load of total effluent generated from MIDC i.e. 33 MLD.
- 2) Non connection of sump No. III to CETP the partially treated effluent (substandard) is being disposed into the sea.
- 3) The operation and maintenance of existing 25 MLD CETP is not upto the mark hence the treated effluent quality is not achieving the standards.

### **Future Expansion of existing 25 MLD CETP**

The source of water supply to industries in Tarapur MIDC is through water supply scheme of MIDC. Average water consumption as metered stands at 41 MLD as per data available from MIDC. In addition the water available from other sources adds to about 7 MLD which is reflected in quantity received at MIDC sumps and pumped to CETP. Thus the effluent as measured at MIDC collection sump stands at ~34 MLD.

The consumption of water is likely to increase in next 18-20 months due to water intensive industries coming up and expansion of existing industries in the area and is estimated to touch 88 MLD.

The effluent generation will then be 62 MLD ( 70% of water consumed) .

The effluent collection system is through MIDC sumps and MIDC pipeline by gravity .At present there are four sumps as described below,

- Sump 1 - approx 6 MLD
- Sump No 2 is used for collection of treated effluent for pumping to sea through BPT.
- Sump 3- approx 6 MLD
- Sump 4- from K & T zones with 2 MLD
- By Gravity - approx 20 MLD

In order to cope up with this TEPS has planned expansion of 12 MLD at plot AM 29 and 25 MLD at plot AM 60.



The design parameters of 12 MLD are based on six months data of 25 MLD CETP and expected COD after sump 3 is fully connected.

The design parameters of 25 MLD would be based on type of industries and characterization of effluent from such industries. It is expected that a number of textile industries are coming up and the levels of COD and BOD may be lower than that of 12 MLD .

The study has been undertaken as part of preparation of DPR of 25 MLD.

#### **2.6.4.3 De-silting of water tanks, drains, rivulets etc.,**

Maharashtra Industrial Development Corporation (MIDC) has given annual maintenance contract Rs. 20 lakhs for arresting leakages of MIDC drainage network from MIDC Tarapur Industrial area.

And is regularly carrying out Desilting of effluent carrying chambers in Tarapur Area. Sludge generated from effluent collection chambers is being disposed to Mumbai waste Management Limited, Taloja a Treatment Storage Disposal Facility. It is noted that around 7700 MT of sludge was disposed to MWML in the year 2009-10.

#### **2.6.4.4 Construction of lined drains/connections**

Maharashtra Industrial Development Corporation is responsible in maintaining of effluent carrying chambers. 59 kilometers of wide effluent carrying pipeline which is of RCC MOC is being maintained by MIDC. Due to leakages in existing pipe lines, MIDC is replacing RCC pipe lines with HDPE pipelines. This replacement of pipeline is around 27 kilometers.

#### **2.6.4.5 Treatment and management of contaminated surface water bodies**

##### **Fresh water**

The nearest fresh water body is being Surya river which is 12 km from MIDC area. It is to be noted that Surya river is supply water to MIDC and industrial and drinking purposes and it has not got contaminated

#### **2.6.4.6 Rejuvenation/management plan for important eco-geological features**

No Rejuvenation/Management plan in place as there are no Eco sensitive areas nearby industrial area.

#### **2.6.4.7 Carrying of effluent from industrial units located in non-industrial locations to CETP facilities by lined drains/pipelines only and prevention of their disposal into city sewerage/surface drains**

There is no industry located in non industrial location. Therefore, No effluent will be carrying out through non Industrial areas.

#### **2.6.4.8 Installation of Gen sets at CETPs.**

Common Effluent Treatment Plant which is under operation is supported by DG set capacity of 625 KVA to continue operations' in case of power failure from MSEDCL. This will be maintained by TEPS.

Also, DG sets are provided as standby for the effluent collection chambers and details of the same is given below . These DG sets operation is being operated by MIDC.

Sump 1. 100 KVA

Sump 2. 200 KVA

Sump 3. 100 KVA

## 2.6.5 Managerial and Financial aspects

### 2.6.5.1 Cost and time estimates

Sr. No.	Planned Action	Responsible Agency	Estimated Cost	Target Date
1	Perused the matter with TEPS CETP to expand the CETP for additional 12 MLD capacity.  TEPS have prepared DPR and appraisal granted by MIDC.  Target date will be given to TEPS to complete the expansion of capacity by end of March. 2011.	CETP	15.94 Crs.	March 2011

#### A) MIDC :-

Sr. No	Planned Action	Responsible Agency	Target Date
1	Board has issued directions to MIDC to stop leakages in the drainage network system.	MIDC	A M C Granted by MIDC
2	Board has issued directions to MIDC to connect sump no 3 to CETP. (Work in progress)	MIDC	Sep. 2010

### 2.6.5.2 Identified private/public sector potential investors and their contribution/obligation

Being Industrial area developed by MIDC, all the infrastructure is being provided by MIDC itself viz., Roads, Lights, Water, Effluent carrying piping etc. CETP is maintained by industrial association namely Tarapur Environmental Protection Society (TEPS) .

### 2.6.5.3 Government Budgetary support requirement

MIDC is responsible to execute any environmental related job in industrial area. Budget required for the same will be managed by MIDC itself

**2.6.5.4 Hierarchical and structured managerial system for efficient implementation**

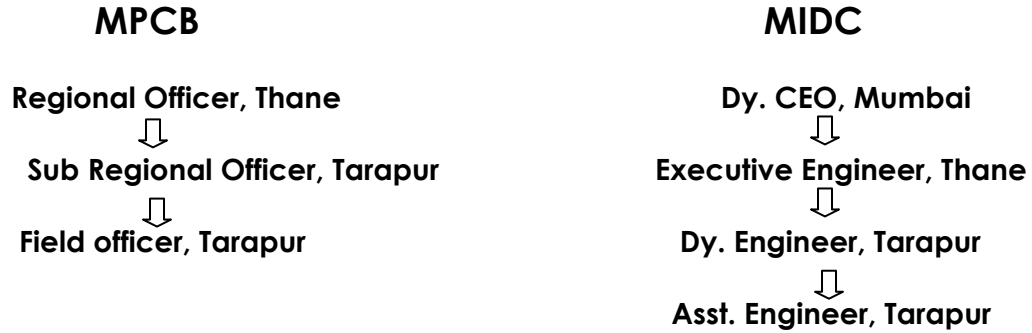

**2.6.6 Self monitoring system in industries (ETPs etc.,)**

Effluent Treatment Plants which are under operation in industrial areas have been designed based on the effluent characteristics. The major treatment units consisting of Primary treatment, Secondary and Tertiary Treatment. Some of the industries are having their own effluent treatment laboratories and third party analysis carried out MOEF Recognized laboratories

**2.6.7 Data linkages to SPCB/CPCB ( of monitoring devices)**

Board has identified 8 Nos. of monitoring location under SWMP. The detail of this location and code number is given below table. This analysis data is already linked with Board website. It is plant to connect the major pollutant sources on real time basis to MPCB, HQ and details are being worked out.

Sr. No.	SWPM MONTHLY SAMPLING LOCATIONS	Sr. No.	GROUND WATER MONITORING LOCATIONS
1	Code No. 140 BPT Navapur Discharge from MIDC Tarapur CROTPI/SWM/10/00023	1	BH-Borewell at Nearlab, K-38, MIDC Tarapur
2	Code No. 141 MIDC Tarapur Nalla near sump No.1 CROTPI/SWM/10/00024	2	BH-4 Borewell at k-61, MIDC Tarapur
3	Code No. 142 MIDC Tarapur Nalla near sump No.2 CROTPI/SWM/10/00025	3	BH-5 Near Suraj Chemical, T-6, MIDC Tarapur

4	Code No. 143 MIDC Tarapur Nalla near sump No.3 CROTPI/SWM/10/00026	4	BH-6 Open space Opp T-108, MIDC Tarapur
5	Code No. 144 Kharekuran Murbe Creek - CROTPI/ SWM/ 10/00027	5	Borewell at Tata Steel, S-76, MIDC Tarapur
6	Code No. 145 Pandi Creek CROTPI/SWM/10/00028	6	Borewell at lalavajapai Wadi (Outside MIDC)
7	Code No. 146 Saravali Creek CROTPI/SWM/10/00029	7	Borewell at M/s. precise Alloys Pvt. Ltd., G-20, MIDC Tarapur
8	Code No. 147 Navapur Sea CROTPI/SWM/10/00030	8	Dhodi Pooja at Boisar Borewell (Outside MIDC)
		9	Borewell at chikuwadi (Outside MIDC)

## Chapter 3

### 3 Air Environment

---

#### 3.1 Present Status of Air environment supported with minimum one year analytical data

##### 3.1.1 Critical locations for air quality monitoring

MPCB has identified industrial zones to monitor National Ambient Quality Monitoring. These are Nzone, T zone and K zone where chemical industries are existed. Ambient Air Quality Monitoring is proposed in the above cited zones. Currently, MPCB is monitoring at its own building.

##### 3.1.2 Present levels of pollutants in air (routine parameters, special parameters and air toxics relevant to the area in three categories-known carcinogens, probable carcinogens and other toxic)

**Table 3.1 Ambient Air Quality Monitoring- Analysis report**

Ambient Air Quality Monitoring Report - MIDC Tarapur				
Year	SO <sub>2</sub>	NOX	RSPM	SPM
2003-2004	32.72	19.83	36.32	112
2004-2005	52.38	45.94	73.6	179.6
2005-2006	62.22	20.11	83.55	112.9
2006-2007	21.58	22.85	90.7	167.4
2007-2008	25.48	35.76	121.1	80.71
2008-2009	27.95	28.61	111.5	261
2009-2010	32	36	165	114

All values are in µg/m<sup>3</sup>

##### 3.1.3 Predominant sources contributing to various pollutants

Most of the textile and chemical industries are using coal as fuel for boiler. Resulting emissions of high particulate matters and gases like SO<sub>2</sub>, NOX etc. beside this there four captive power plants which are using coal as fuel. There are chemical industries which are emitting gases arising from the chemical reactions carried out during the manufacturing process. Some of the industry has provided the scrubbing system for process emission also some of the coal fired

boiler industries have provided multi cyclone separator / wet scrubber. However, due to inadequate capacity / improper operation & maintains of air pollution control equipment air pollution problem is existing. The details of fuel burning patterns and SO<sub>2</sub> emissions are as below

- i) No. of Coal fired boiler industries :- 32 Nos
- ii) Total Coal consumption by the factories :- 804 T/D
- iii) Total furnace oil consumption by the factories :- 170 T/ Day
- iv) Total LDO consumption by the factories :- 51.27 T / Day
- v) Amount of SO<sub>2</sub> due to burning of coal / FO / LDO :- 25.74 T/Day

### **3.2 Sources of air pollution viz. industrial, domestic( coal & Biomass burning), natural and Transport & Heavy Earth Movers)**

As there are lot of Engineering units , there is a heavy movement of continuous transportation of vehicles plying in and around industrial area. In order to control vehicle pollution, Road network needs to be improved by MIDC. Currently, MIDC Tarapur industrial area is having aspalted 63.0 km of road network and work of concreting road network has taken up by MIDC authority for stretch of 3.0 km has already been completed

### **3.3 Air Polluting industries in the area/cluster**

There are major textiles units which are using coal as fuel in addition to CPP exist contributing particulate matter emissions. Total coal consumption in MIDC by the factories is 80.6 MT per day.

Apart from textile, there are chemical/ pharmaceutical industries which are using furnace oil as a fuel. Total consumption of furnace oil is 170.0 MT per day contributing So<sub>2</sub>.

LDO is also being consumed by chemical industries. Consumption of LDO is 51.27 MT per day contributing to So<sub>2</sub> emissions.

Total So<sub>2</sub> emissions due to usage of furnace and LDO and Coal are 25.74 MT per day.

### **3.4 Impact of activities of nearby area on the CEPI Area**

Municipal solid waste is generated in and around Tarapur industrial area. Currently, there is no proper management of MSW. It is observed that Municipal solid waste generated is being transported to outside industrial area within 1.0 km from MIDC where it is dumped illegally and burnt without having any control. The emissions generated from this illegal act may impact on CEPI area.

### **3.5 Quantification of the air pollution load and relative contribution by different sources**

Air pollution in this industrial area is being particulate matter and Sulphur dioxide. So<sub>2</sub> emissions due to usage of furnace oil, LDO and coal are 25.74 MT per day.

There are chemical and engineering industries using various chemicals/acids which will generate various fugitive emissions which are contributing to air pollution

### **3.6 Action plan for compliance and control of pollution**

#### **3.6.1 Existing infrastructure facilities-Ambient air quality monitoring network**

MPCB has identified 3 Ambient air Quality monitoring stations in MIDC taking critical industrial cluster into consideration. These are N-zone, T zone and K zone where chemical industries are existed. However, Ambient Air Quality Monitoring is being conducted at MPCB office.

#### **3.6.2 Pollution control measures installed by individual sources of pollution**

There are 32 nos of industries are using coal as a fuel. These industries have provided with air pollution control devices. List of industries using coal as fuel is given in Table 3.2



**Table 3.2 List of industries using coal as fuel and APCs**

<b>Sr. No.</b>	<b>Name of Industry</b>	<b>Plot No.</b>	<b>Coal Consumption MT/Day</b>	<b>Air Pollution Control devices Provided</b>
1	Angadpal Industries Ltd.	H-4/3	15	Multi cyclone, Wet scrubber
2	Arati Drugs Ltd.	N-198	16	Multi cyclone, Wet scrubber
3	Arati Industries Ltd.	K-17	4	Multi cyclone, Wet scrubber
4	Balakrishna Industries Ltd.	H-3/1	20	Multi cyclone, Wet scrubber
5	Bombay Rayon Fashion Ltd.	C-7	50	Multi cyclone & ESP
6	Detco Textiles Pvt. Ltd.	E-30	6	Multi cyclone, Wet scrubber
7	Dhanasingh Textile Pvt. Ltd.	G-3/3	3.5	Multi cyclone, Wet scrubber
8	Dicitex Décor Export	G-7/1	25	Multi Cyclone
9	Dicitex Décor Pvt. Ltd.	F-6/1	7	Multi Cyclone
10	Dicitex Décor Pvt. Ltd.	G-15/1	20	Multi Cyclone
11	G. M. Textile Ltd.	E-37/2	22	Multi cyclone, Wet scrubber, dust collector
12	Gini Silk Mill Ltd.	E-15	20	Multi cyclone, Wet scrubber
13	J. B. Textile Pvt. Ltd.	E-46	8	Dust collector
14	Jindal Steel Work	B-6	400	ESP followed - 80 mtr
15	K. P. Chemicals	L-63	8	Dust collector
16	Kriplion Synthetics Pvt. Ltd.	N-97	10	Multi cyclone, Wet scrubber
17	Mandhana Dyeing	E-25	22	Multi cyclone, Wet scrubber
18	Manohar Processor Pvt. Ltd.	G-7/2/2	14	Multi cyclone, Wet scrubber,
19	Mudra Life Styles Ltd.	D-1	25	Dust Collector followed by bag filter
20	Nupur	D-17	16	Multi cyclone
21	Resonace Speciality Ltd.	T-140	5	Multi cyclone, Wet scrubber
22	Rolson Textile	E-8	22	Multi cyclone, Wet scrubber
23	Samarth Knioffers Pvt. Ltd.	H-4/1	16	Multi Cyclone
24	Siyaram Silk Mills Ltd.	G-1/1	3.5	Multi cyclone, Wet scrubber

25	Slivester Textile Ltd.	E-24	12	Multi cyclone, Wet scrubber
26	Usha Fashion	E-42	5	Multi cyclone, Wet scrubber
27	Vallant Glass	J-117	23	Cyclone dust collector
28	Zeus International	A-10	6	Multi cyclone, Wet scrubber
	<b>Total</b>		<b>804 Ton/Day</b>	

### **3.6.3 Technological intervention**

#### **3.6.3.1 inventorisation of prominent industries with technological gaps**

Most of the chemical units are using various types of solvents and chemicals. Resulting generation of fugitive emissions/VOC's while handling this solvents/chemicals. Presently, monitoring of VOC's and fugitive emissions is a technological gap which needs standard methods and equipment and expertise.

Board is planning to carry out training programs for proper operation & maintains of air pollution control equipments from coal fired industries and chemical industries handling solvents.

#### **3.6.3.2 Identification of low cost and advanced cleaner technology for air pollution control**

There is no low cost technology available for air pollution control. However, alternative fuel such as CNG may be used as fuel in place of coal/ FO/LDO to have cleaner production

#### **3.6.3.3 Introduction and switch over to cleaner fuel**

Tarapur Industrial Manufacturing Association (TIMA) has initiated to make it available of CNG to Tarapur industrial area. In this regard, TIMA has initiated proactive steps such as taking requirement of fuel being used in individual industries.

### 3.6.4 Need of infrastructure Renovation

#### 3.6.4.1 Development of roads

The responsibility of maintaining of good road inside industrial area lies with MIDC. Currently, 63.0 kilometers of road has been asphalted and 3.0 kilometers has been concreted.

#### 3.6.5 Impact on CEPI score after installation /commissioning of full fledged air pollution control system

Board has decided to carry out the monitoring survey of stack emissions within the period of 4 months i.e. December-2010 to identify adequacy of existing pollution control equipments. After this survey the direction will be given to the defaulting industries to up-grade the air pollution control equipments to giving the target of December-2011.

After implementation of Short Term and Long Term Action Plan the CEPI for Water Environment is expected to come down from 60.75 to 33.25. The scenario of the CEPI after implementation of estimated as under :-

- Short Term:

	A1	A2	A	B1	B2	B3	B	C1	C2	C3	C	D
Existing	5.75	5.0	28.75	2.0	3.0	3.0	8.0	3.0	3.0	5.0	14.0	10.0
After ST	4.75	5.0	23.75	1.5	3.0	2.0	6.5	3.0	2.0	5.0	11.0	5.0

- Air CEPI will be reduced from 60.75 to 46.25 after Short Term Action Plan

- Long Term

	A1	A2	A	B1	B2	B3	B	C1	C2	C3	C	D
After LT	3.0	5.0	15.0	1.5	3.0	2.0	6.5	3.0	1.0	4.0	7.0	4.0

- Air CEPI will be reduced from 46.25 to 33.25 after :Long Term Action Plan

### 3.6.6 Managerial and Financial aspects-Cost and time estimates

#### 3.6.6.1 Cost and time estimates

Sr. No	Planned Action	Responsible Agency	Target Date
1	Matter will be pursued with Mahanagar Gas limited/ GAIL to make available the natural gas to the industries in MIDC Tarapur area. Target date to supply gas will be three years.	Mahanagar Gas/GAIL	March 2013
2	The proposal of installation of continuous ambient air quality monitoring system under CPCB scheme is submitted.	MPCB/CPCB	March 2012

#### 3.6.6.2 Identified private/public sector potential investors & their contribution / obligation

Tarapur Industrial Manufacturing Association (TIMA) has initiated to make it available of CNG to Tarapur industrial area. In this regard, TIMA has initiated proactive steps such as taking requirement of fuel being used in individual industries.

#### 3.6.6.3 Government Budgetary support requirement

Board has proposed continuous Ambient Air Quality monitoring with meteorological data in Tarapur industrial area. Proposal has already been submitted. The tentatively Budget requirement for this proposal is approx. 5.0 cr.

#### 3.6.6.4 Hierarchical and structured managerial system for efficient implementation

##### MPCB

Regional Officer, Thane



Sub Regional Officer, Tarapur



Field officer, Tarapur (3 Nos.)

### **3.6.7 Self monitoring system in industries (Stacks, APCDs)**

Major industries are self monitoring of their emissions and Ambient Quality through MOEF recognized laboratories periodically.

### **3.6.8 Data linkages to SPCB/CPCB (of monitoring devices)**

National Ambient Air Quality monitoring data was linked to board website in past. Currently, Linkage has temporarily been deferred.

## Chapter 4

### 4 Land Environment (Soil and Ground water)

---

#### 4.1 Soil Contamination

##### 4.1.1. Present Status of land environment supported with minimum one year analytical data

MIDC developed 59.0 kilometers of RCC drainage network in Tarapur industrial since inception of MIDC. RCC drainage network has been damaged and got leakages. MIDC has started replacing the damaged RCC drainage with HDPE to the extent of 27.0 kilometers.

This leakage of drainage may be sources of soil contamination. Data in this regard is not available.

##### 4.1.1 Critical locations for land/soil pollution assessment and ground water monitoring

Board has identified 8 Nos. of monitoring location under SWMP and 9 Nos. of ground water monitoring location. The detail of this location and code number is given as below. This analysis data is already linked with Board website. Details of the same is given in Table 4.1

**Table 4.1 SWMP/Ground water monitoring stations**

Sr. No.	SWPM MONTHLY SAMPLING LOCATIONS	Sr. No.	GROUND WATER MONITORING LOCATIONS
1	Code No. 140 BPT Navapur Discharge from MIDC Tarapur CROTPI/SWM/10/00023	1	BH-Borewell at Nearlab, K-38, MIDC Tarapur
2	Code No. 141 MIDC Tarapur Nalla near sump No.1 CROTPI/SWM/10/00024	2	BH-4 Borewell at k-61, MIDC Tarapur
3	Code No. 142 MIDC Tarapur Nalla near sump No.2 CROTPI/SWM/10/00025	3	BH-5 Near Suraj Chemical, T-6, MIDC Tarapur

4	Code No. 143 MIDC Tarapur Nalla near sump No.3 CROTPI/SWM/10/00026	4	BH-6 Open space Opp T-108, MIDC Tarapur
5	Code No. 144 Kharekuran Murbe Creek - CROTPI/ SWM/ 10/00027	5	Borewell at Tata Steel, S-76, MIDC Tarapur
6	Code No. 145 Pandi Creek CROTPI/SWM/10/00028	6	Borewell at lalavajapai Wadi (Outside MIDC)
7	Code No. 146 Saravali Creek CROTPI/SWM/10/00029	7	Borewell at M/s. precise Alloys Pvt. Ltd., G-20, MIDC Tarapur
8	Code No. 147 Navapur Sea CROTPI/SWM/10/00030	8	Dhodi Pooja at Boisar Borewell (Outside MIDC)
		9	Borewell at chikuwadi (Outside MIDC)

**4.1.2 Present levels of pollutants in land/soil and ground water (routine parameters, special parameters and water toxics relevant to the area in three categories-known carcinogens, probable carcinogens and other toxic)**

Board is monitoring Ground water quality half yearly from the above locations. However, pollutants levels in land and soil are not available.

**4.1.3 Predominant sources contributing to or posing danger of pollution of land and ground water such as hazardous/toxic wastes or chemicals dumps/ storage etc.,**

The hazardous waste was dumped by the factories located in MIDC Tarapur Industrial Area at various locations such as K-Zone, 70 Bungalow area and many other places prior to 2005 has been collected and stored in secured engineering land fill site at K-Zone in 2006. The total quantum of waste kept at this secured land fill is 1,50,000 MT. costing 5.0 cr.

This may be one of the predominant sources of land and ground water pollution in the industrial area.

Board is monitoring illegal hazardous waste dumps. Some of the industries have been fined for illegal dump and proper action taken by sending illegal hazardous waste to CHWTSDf.

#### **4.1.4 Sources of soil contamination**

Illegal dumping of hazardous waste dumps in past and Municipal solid waste dumps. There are 6 villages in and around MIDC contributing 10-12 MT of Municipal solid waste and presently dumps at adjacent to Suttar bungalow.

Other sources are overflowing of effluent from sumps and leakages from chambers and pipe lines.

**A view of Illegal dump site of Municipal solid waste is shown**





**A view of MIDC drainage leakage further meeting to Murbe creek**



**A view of MIDC drainage leakage further meeting to Murbe creek**



#### **4.1.5 Types of existing pollution**

Leakages from drainage system

Leachate from illegal dumps of Municipal solid waste

Leachate from past illegal dumps of hazardous waste (Prior – 2005)

#### **4.1.6 Remedies for abatement, treatment and restoration of normal soil quality**

Maharashtra Industrial Development Corporation is having 59 kilometers of wide effluent carrying pipeline which is of RCC MOC is being maintained by MIDC. Due to leakages in existing pipe lines, MIDC is replacing RCC pipe lines with HDPE pipelines. This replacement of pipeline is around 27 kilometers is completed. And the work of replacement of HDP pipeline 6 km. costing Rs. 110 Lakhs by 2010-2011, replacement of another 9 km. costing Rs. 1800 lakhs by 2011-2012 is planned Phase wise by the MIDC authority.

All industries have become a member of common hazardous waste Treatment Storage and Disposal facility (CHWTSDF) and are regularly disposing their waste to facility.

## Monitoring

### 4.2 Ground water contamination

#### 4.2.1 Present Status/quality of ground water

**Table 2.2 Ground Water Quality Analysis Report from MIDC Tarapur Area (2008-2010)**

Name of the monitoring station	(2008-2009)								(2009-2010)							
	PH	CaCo3	Cl	DO	BOD	COD	SO4	Nitrate	PH	Caco3	Cl	DO	NO3	SO4	BOD	COD
	Avg	Avg	Avg	Avg	Avg	Avg	Avg	Avg	Avg	Avg	Avg	Avg	Avg	Avg	Avg	Avg
1) Bore well at M/s. Tata steel s-76	7.5	444	151	7	4.1	26	91	0.4	7.4	476	356	5.9	3.16	62.59	22	16
2) Bore well at M/s Precise	7.7	535	204	7.2	3.5	36	118	7.18	7.85	626	244	5.1	0.11	0.18	24	13
3) Bore well at dhodi pooja	7.5	429	139	7	4.2	26	92.2	0.42	7.41	342	299	7.8	0.01	0.07	26	12
4) Bore well at chandnika Magar	7.9	493	195	7.1	4.6	22	113	7.58	7.9	725	475	5.75	2.24	26.65	5.5	21
5)Bore well at chikuwadi	7.5	445	147	6.8	6.7	38	92.4	0.47	7.58	350	94	5.5	0.01	30.09	26	11
6)Bore well at Lauaraj paiwadi	7.2	575	179	6.2	4	32	91.2	7.8	7.6	723	303	5.8	18.1	93.05	5.6	24

**All values are in mg/l. except pH.**

### Source identification (existing sources of ground water pollution)

Board has not having definite data of impact area for ground water pollution. However, possibility of pollution due to the following sources may not be ruled out.

Illegal dumping of hazardous waste dumps in past and Municipal solid waste dumps. There are 6 villages in and around MIDC contributing 10-12 MT of Municipal solid waste and presently dumps at adjacent to Suttar bungalow.

Other sources are overflowing of effluent from sumps and leakages from chambers and pipe lines.

#### 4.2.2 Ground water quality monitoring programme

Board has identified 8 Nos. of monitoring location under SWMP. The detail of this location and code number is given below table. This analysis data is already linked with Board website. It is plant to connect the major pollutant sources on real time basis to MPCB, HQ and details are being worked out.

Sr. No.	SWPM MONTHLY SAMPLING LOCATIONS	Sr. No.	GROUND WATER MONITORING LOCATIONS
1	Code No. 140 BPT Navapur Discharge from MIDC Tarapur CROTPI/SWM/10/00023	1	BH-Borewell at Nearlab, K-38, MIDC Tarapur
2	Code No. 141 MIDC Tarapur Nalla near sump No.1 CROTPI/SWM/10/00024	2	BH-4 Borewell at k-61, MIDC Tarapur
3	Code No. 142 MIDC Tarapur Nalla near sump No.2 CROTPI/SWM/10/00025	3	BH-5 Near Suraj Chemical, T-6, MIDC Tarapur
4	Code No. 143 MIDC Tarapur Nalla near sump No.3 CROTPI/SWM/10/00026	4	BH-6 Open space Opp T-108, MIDC Tarapur
5	Code No. 144 Kharekuran Murbe Creek - CROTPI/ SWM/ 10/00027	5	Borewell at Tata Steel, S-76, MIDC Tarapur
6	Code No. 145 Pandi Creek CROTPI/SWM/10/00028	6	Borewell at lalavajapai Wadi (Outside MIDC)
7	Code No. 146 Saravali Creek CROTPI/SWM/10/00029	7	Borewell at M/s. precise Alloys Pvt. Ltd., G-20, MIDC Tarapur

8	Code No. 147 Navapur Sea CROTPI/SWM/10/00030	8	Dhodi Pooja at Boisar Borewell (Outside MIDC)
		9	Borewell at chikuwadi (Outside MIDC)

#### **4.2.3 Action plan for control of pollution including cost/ time aspects**

The hazardous waste was dumped by the factories located in MIDC Tarapur Industrial Area at various locations such as K-Zone, 70 Bungalow area and many other places prior to 2005 has been collected and stored in secured engineering land fill site at K-Zone in 2006.

Board had initiated to for encapsulation of secured land fill .The total quantum of waste kept at this secured land fill is 1,50,000 MT. costing 5.0 cr. This may be one of the predominant sources of land and ground water pollution in the industrial area.

Board is monitoring illegal hazardous waste dumps. Some of the industries have been fined for illegal dump and proper action taken by sending illegal hazardous waste to CHWTSDf.

#### **4.2.4 Treatment and management of contaminated ground water bodies etc.,**

Board has identified 8 Nos. of monitoring location under SWMP. These points will be monitored.

#### **4.2.5 Impact on CEPI score after abatement of pollution**

MIDC has proposal to replace the old pipe line with new pipe line of HDPE in two phase of total cost 29 crores target date for the completion of said work is April-2011 and April-2012 for phase-I & Phase-II respectively.

After implementation of Short Term and Long Term Action Plan the CEPI for land Environment is expected to come down from 51.25 to 48. The scenario of the CEPI after implementation of estimated as under :-

- **For Land Environment:**

	A <sub>1</sub>	A <sub>2</sub>	A	B <sub>1</sub>	B <sub>2</sub>	B <sub>3</sub>	B	C <sub>1</sub>	C <sub>2</sub>	C <sub>3</sub>	C	D
Existing	3.0	5.0	15.0	7.75	3.0	3.0	13.75	5.0	1.5	0.0	7.5	15.0
After ST	2.5	5.0	12.5	7.0	3.0	3.0	13.00	5.0	1.5	0.0	7.5	15.0

- **Land CEPI = 51.25**
- $A = A_1 \times A_2$ , A<sub>1</sub> : Presence of Toxin, A<sub>2</sub>: Scale of Industrial Activities
- $B = B_1 + B_2 + B_3$  B<sub>1</sub>: Pollution Concentration, B<sub>2</sub> Impact on People , B<sub>3</sub> Impact on Eco-geological Features .
- $C = C_1 \times C_2 + C_3$  , Where C<sub>1</sub> = Potential Affected Population C<sub>2</sub>= Level of Exposure, C<sub>3</sub>=Risk to Sensitive Receptor .
- D= Additional High Risk Element.

### 4.3 Solid waste Generation and management

#### 4.3.1 Waste classification and quantification

##### 4.3.1.1 Hazardous waste

All industry generating hazardous waste in MIDC Tarapur Industrial Area has become member of CHWTSDf, Taloja and is regularly sending their hazardous waste to facilities.

- I) No. Industries generating Hazardous Waste: - 407 Nos.
- II) No. of Industries member of CHWTSDf: - 407 Nos.
- III) Quantity of Hazardous Waste dispose to MWML Taloja facility during last 1<sup>st</sup> April'2009 to March'2010 is 12890.9 MT

##### 4.3.1.2 Bio-medical waste

There are only 4 hospitals in MIDC Tarapur. Bio Medical waste generated from this Hospitals 338 kg/year and all the Hospitals have become member of CHWTSDf (Touch and Glow, Palghar).

#### **4.3.1.3 Electronic waste**

No data is available on disposal of electronic waste. However, ISI /MSI industries are having their disposal mechanism by way of sending back to suppliers.

#### **4.3.1.4 Municipal solid waste /domestic waste/ sludges from ETPs, /CETPs/STPs and other industrial sources**

##### **Municipal Solid waste/domestic waste**

There are 6 villages in and around MIDC Tarapur industrial area. The aprox. quantity of Municipal waste is 10.-12 Mt per day which is not treated and disposed scientifically

##### **Sludge from ETPs/CETPs**

All industries have become member of CHWTSDF and wastes generated will be disposed to CHWTSDF.

#### **4.3.1.5 Plastic wastes**

No data is available in disposing plastic wastes. It is mixed with Municipal solid wastes.

#### **4.3.1.6 Quantification of wastes and relative contribution from different sources**

No quantification of wastes from other sources

#### **4.3.2 Identification of waste minimization and waste exchange options**

Industries are working on waste minimization practices under different CREP guidelines.

#### **4.3.3 Reduction /Reuse/Recovery/Recycle options in the co processing of wastes**

**Reuse, Recycle reduction in pollution load and adoption of clean technology.**



**+ RO Plant: - The following plants have provided advanced treatment technology such RO for reuse of waste water.**

- M/s JSW Steel Ltd., Plot No. B-6, MIDC, Tarapur, Boisar, Tal : Palghar, Dist : Thane - 401506, have provided RO of capacity 300 CMD.
- M/s. Sunway Textile Ltd, Plot No.G-21,have provided RO of capacity 3 KL / Day

**+ Caustic Recovery Plant :- the following plants have provided the caustic recovery plant**

- M/s. Mudra lifestyle limited, Plot No. D-1, MIDC,Tarapur, Boisar, Tal.Palghar, Dist :-Thane- 401506, have provided caustic recovery plant of capacity 10 Kl/hr.
- M/s. Bombay Rayon Fashion Ltd. Plot No C-6 & C-7 MIDC, Tarapur, Taluka-Palghar, Dist- Thane., have provided caustic recovery plant of capacity 24 Kl/hr.

**+ Multi Effective Operator**

- M/s. Nipur Chemicals, Plot No. D-17, MIDC, Tarapur, Boisar, Tal. Palghar, Dist:-Thane- 401506, have provided multi effective operator for the concentration of rich stream generated from H-Acid manufacturing plant.

**+ Waste Pickle Recovery**

- M/s. Indorex Global Pvt Ltd, Plot No. B-11, MIDC,Tarapur, Boisar, Tal.Palghar, Dist :-Thane- 401506, have provided acid recovery plant of capacity 4.5Kl/Hr. The waste pickle from M/s.TATA Steel Ltd and M/s.JSW Ltd is treated at this plant.

**+ Recovery of Ammonium Sulphate**

- M/s. Arti Drugs Ltd, Plot No. N-198, MIDC, Tarapur, Boisar, Tal. Palghar, Dist :-Thane- 401506. This industry has developed new technology for the recovery of ammonium sulphate 2000 Mt / month by unit operation like evaporation, crystallization. Earlier the same was treated in their ETP.
- Camlin Fine Chemicals. Ltd., Plot No. D, MIDC Tarapur has proposed segregation of high COD.
- M/s. Arti Industries Ltd., E-50, has installed zero discharge plant such as incineration high COD.



#### **4.3.4 Infrastructure facilities**

##### **4.3.4.1 Existing TSD/Incineration facilities including capacities**

The hazardous waste was dumped by the factories located in MIDC Tarapur Industrial Area at various locations such as K-Zone, 70 Bungalows area and many other places prior to 2005 has been collected and stored in secured engineering land fill site at K-Zone in 2006. The total quantum of waste kept at this secured land fill is 1,50,000 MT. The present photographs of this site are as shown below:-

**A view of Hazardous waste Encapsulation site at K zone of MIDC Tarapur.**



**A view of Hazardous waste Encapsulation site at K zone of MIDC Tarapur**



**A view of Hazardous waste Encapsulation site at K zone of MIDC Tarapur**



All industry generating hazardous waste in MIDC Tarapur Industrial Area has become member of CHWTSDf, Taloja and is regularly sending their hazardous waste to facilities.

- I) No. Industries generating Hazardous Waste: - 407 Nos.
- II) No. of Industries member of CHWTSDf: - 407 Nos.
- III) Quantity of Hazardous Waste dispose to MWML Taloja facility during last 1<sup>st</sup> April'2009 to March'2010 is 12890.9 MT

There is no Municipal solid waste management facility available for the 6 nos. of village generating there municipal waste to a tune of 10-12 MT/Day.

#### **4.3.4.2 Present status/performance and need of up-gradation of existing facilities including enhancement of capacities**

The existing CHWTSDf located in Taloja is under operation and having scientific landfill and incineration facilities.

#### **4.3.4.3 Treatment and management of contaminated waste disposal sites etc.,**

The hazardous waste was dumped by the factories located in MIDC Tarapur Industrial Area at various locations such as K-Zone, 70 Bungalows area and many other places prior to 2005 has been collected and stored in secured engineering land fill site at K-Zone in 2006. The total quantum of waste kept at this secured land fill is 1,50,000 MT

#### **4.3.4.4 Impact on CEPI score after proper management of solid wastes.**

MIDC has proposal to replace the old pipe line with new pipe line of HDPE in two phase of total cost 29 crores target date for the completion of said work is April-2011 and April-2012 for phase-I & Phase-II respectively.

After implementation of Short Term and Long Term Action Plan the CEPI for land Environment is expected to come down from 51.25 to 48. The scenario of the CEPI after implementation of estimated as under :-

- For Land Environment:

	A1	A2	A	B1	B2	B3	B	C1	C2	C3	C	D
Existing	3.0	5.0	15.0	7.75	3.0	3.0	13.75	5.0	1.5	0.0	7.5	15.0
After ST	2.5	5.0	12.5	7.0	3.0	3.0	13.00	5.0	1.5	0.0	7.5	15.0

- Land CEPI = 51.25
- $A = A1 \times A2$ , A1 : Presence of Toxin, A2: Scale of Industrial Activities
- $B = B1 + B2 + B3$  B1: Pollution Concentration, B2 Impact on People , B3 Impact on Eco-geological Features .
- $C = C1 \times C2 + C3$  , Where C1 = Potential Affected Population C2= Level of Exposure, C3=Risk to Sensitive Receptor .
- D= Additional High Risk Element.

# Chapter 5

## 5 PPP model

### **5.1 Identification of project proposals (for both the options i.e. technology intervention and infrastructure renewal)for implementation under the PPP mode under the Action plan**

MIDC has developing authority in Tarapur. Hence, there is no PPP model which is currently working in this industrial cluster

### **5.2 Identification of stakeholders/agencies to be involved and to evolve financial and managerial mechanisms for implementation of PPP projects**

MIDC has developing authority in Tarapur. Hence, there is no PPP model which is currently working in this industrial cluster

# Chapter 6

## **6 Other infrastructural Renewal measures**

### **6.1 Green Belts**

Tarapur Industrial area is developed in 1100 hectares of land out of which 10% land is reserved for open area and being planned for Green belt development

### **6.2 Development of industrial Estate(s)**

There is no expansion of Industrial area in near future because of restriction of TAPS (Tarapur Atomic power Station)

### **6.3 Development /shifting of industries located in the non-industrial areas to existing /new industrial estates**

No shifting of industries located in the non-industrial areas to existing/new industrial estates

# Chapter 7

## **7 Specific schemes**

### **7.1 GIS-GPS system for pollution sources monitoring**

MWML is facility Taloja has developed GPS monitoring model for tracking of transportation of hazardous wastes

### **7.2 Hydro-geological fracturing for water bodies rejuvenation**

### **7.3 In-situ remediation of sewage**

20.0 MLD of sewage is generated from 6 villages in and around of MIDC. To set up a Sewage treatment plant, Approx. Rs. 10-12 cr investment is required to set up STP and Rs. 15.0 cr is required for operating STP per annum

### **7.4 Utilization of MSW inert by gas based brick kilns**

Presently, there is no segregation of MSW.

### **7.5 Co-processing of wastes in cement industries**

M/s Nupur chemicals D-17 MIDC is sending their gypsum waste as a raw material to cement industries about 65000 MT has been disposed to cement industries till to date.

Bottom ash generated from Coal fired boilers are being utilized by local brick manufacturing. Around 120 MT per day of bottom ash is being utilized.

## Chapter 8

### **8 Public awareness and training programs**

Board is actively participating in various public awareness programs during Festivals such as Ganesh Chaturdi, Holi, dassara and World Environment Day through poster campaign, Media publicity etc.,



## Chapter 9

### **9 Overall impact of installation / commissioning of pollution control equipments / measures on the CEPI score**

Capacity wise expansion of existing 25 MLD TEPS - CETP by additional 12 MLD and proposed 25 MLD will definitely bring down CEPI score. Similarly, using CNG will also bring down CEPI score

## Chapter 10

### **10 Assessment of Techno-economical feasibility of pollution control systems in clusters of small/medium scale industries**

Assessment of expanding existing CETP has already been done and found its feasibility. Changing fuel from existing coal/FO/LDO to CNG is yet to be studied though, TIMA has initiated the study

## Chapter 11

**11 Efforts shall be made to encourage use of Bio-compost and Bio-fertilizer along with the chemical fertilizer in the state to minimize the unutilized chemical fertilizer run off into the natural water resources from agriculture fields (through Govt. Policy)**

Currently, M/s Lupin Limited is involving in bio composting process. The process mycelia waste generated from fermentation is being composted and converted to useful manure around 250 tons per month. This kind of initiative needs to be encouraged.

## Chapter 12

### 12 Summary of proposed action points

#### 12.1 Short Term Action Points ( upto 1 year, including continuous activities)

S. No.	Action points (including source & mitigation measures)	Responsible stake holders	Time limit	Cost	Remarks
<b>Water Pollution control</b>					
1.	Expansion of TEPS CETP from existing 25 MLD to 37 MLD (Expansion -12MLD)	TEPS and MIDC	March 2011	15.94 Cr.	DPR is approved by NEERI but, Local villagers have opposed this expansion
2.	Arresting leakage of drainage pipe line	MIDC	Every financial year	20.0 lacs	AMC is granted by MIDC
3.	Connection Sump III to CETP	MIDC	Dec' 2010	-	Work has already started and near completion
4.	Identification of Solvent Use & solvent recovery plant	MPCB	3 Month	-	-
5.	To Improve the efficiency of solvent recovery by solvent using industries	Individual industry	One year	-	Efficiency shall be improved more than 95%
<b>Air Pollution control</b>					
6.	Survey of stack monitoring	MPCB	Dec' 2010	5 lacs	Monitoring of coal fired boilers and process stacks
7.	Identification of Solvent Use & solvent recovery plant	MPCB	3Month	-	-

8.	To Improve the efficiency of solvent recovery by solvent using industries	Individual industry	One year	-	Efficiency shall be improved more than 95%
<b>Soil pollution control</b>					
9.	Arresting leakages from existing drainage network	MIDC	-	20.0 lacs	AMC is granted by MIDC
10.	Illegal dumping of hazardous waste	MPCB	-	-	Board has fined two industries in the past 6 months
11	Massive Tree Plantation (One lacs Trees)	MIDC	Every year	-	MIDC shall carry out massive tree plantation program on empty/reserved plots, and on boundary of MIDC area

### 12.2 Long Term Action Points (ore than 1 year)

S. No.	Action points (including source & mitigation measures)	Responsible stake holders	Time limit	Cost	Remarks
<b>Water Pollution control</b>					
1.	If outlet treated quality is not achieved, advanced technologies such as MBR/RO are to be enforced	TEPS CETP	March 2012	-	Capital and running cost of of RO will be high
2.	Replacement of RCC drainage by HDPE	MIDC	2010-11	1100 lacs	Replacement of 6.0 km pipe line
3.	Replacement of RCC drainage by HDPE	MIDC	2011-12	1800 lacs	Replacement of 9 km pipe line
4.	Augmentation of sump no. 1 holding capacity	MIDC	2011-12	300 lacs	Capacity of 1500 m3
5.	Augmentation of pumping machinery at sump 1 & 2	MIDC	2010-11	100 lacs	Replacement of pumping machineries

6.	Extension of pipeline inside Navapur sea	MIDC	2011-12		NIO has studied pre and post monsoon studied and report is awaited
7.	Reuse and recycle of treated water by the textile industries	MPCB	March-2012	-	-
8	Massive Tree Plantation (One lacs Trees)	MIDC	Every year	-	MIDC shall carry out massive tree plantation program on empty/reserved plots, and on boundary of MIDC area

#### **Air Pollution control**

9	Pursuing matter with Mahanagar Gas limited/ GAIL to make available CNG to MIDC Tarapur	Mahana gar Gas / GAIL	March 2013	-	TIMA has already started survey for requirement.
10	Proposal of installation of continuous Ambient Air Quality monitoring under CPCB scheme	CPCB/MP CB	March 2012	Approx 5.0 Crs	Proposal has already submitted

#### **Soil Pollution control**

11	Replacement of RCC drainage by HDPE	MIDC	2010-11	1100 lacs	Replacement of 6.0 km pipe line
12.	Replacement of RCC drainage by HDPE	MIDC	2011-12	1800 lacs	Replacement of 9 km pipe line
13	Augmentation of sump no. 1 holding capacity	MIDC	2011-12	300 lacs	Capacity of 1500 m3
14	Augmentation of pumping machinery at sump 1 & 2	MIDC	2010-11	100 lacs	Replacement of pumping machineries
15	Massive Tree Plantation (One lacs Trees)	MIDC	Every year	-	MIDC shall carry out massive tree plantation program on empty/reserved plots, and on boundary of MIDC area